



Bamboo Wine Set Design : Ancient Chinese Craft Intellectual Heritage to new design

Zhikai Zhang

A Thesis Submitted in Partial Fulfillment of Requirements for  
degree of Master of Arts in Fine and Applied Arts Research and Creation  
December 2024

Copyright of Mahasarakham University

Bamboo Wine Set Design : Ancient Chinese Craft Intellectual Heritage to new design

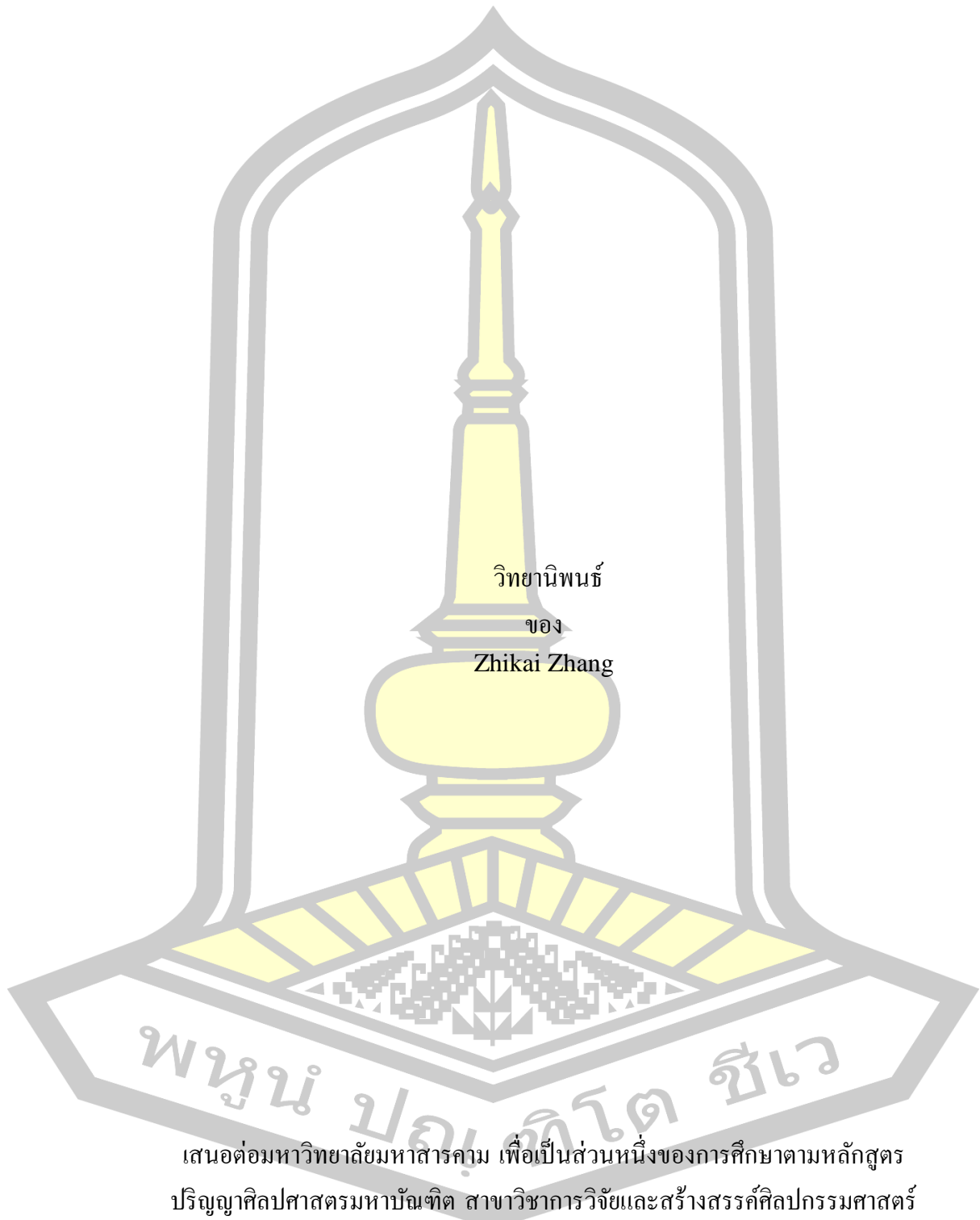

เสนอต่อมหาวิทยาลัยมหาสารคาม เพื่อเป็นส่วนหนึ่งของการศึกษาตามหลักสูตร  
ปริญญาศิลปศาสตรมหาบัณฑิต สาขาวิชาการวิจัยและสร้างสรรค์ศิลปกรรมศาสตร์

ธันวาคม 2567

ลิขสิทธิ์เป็นของมหาวิทยาลัยมหาสารคาม

Bamboo Wine Set Design : Ancient Chinese Craft Intellectual Heritage to new design

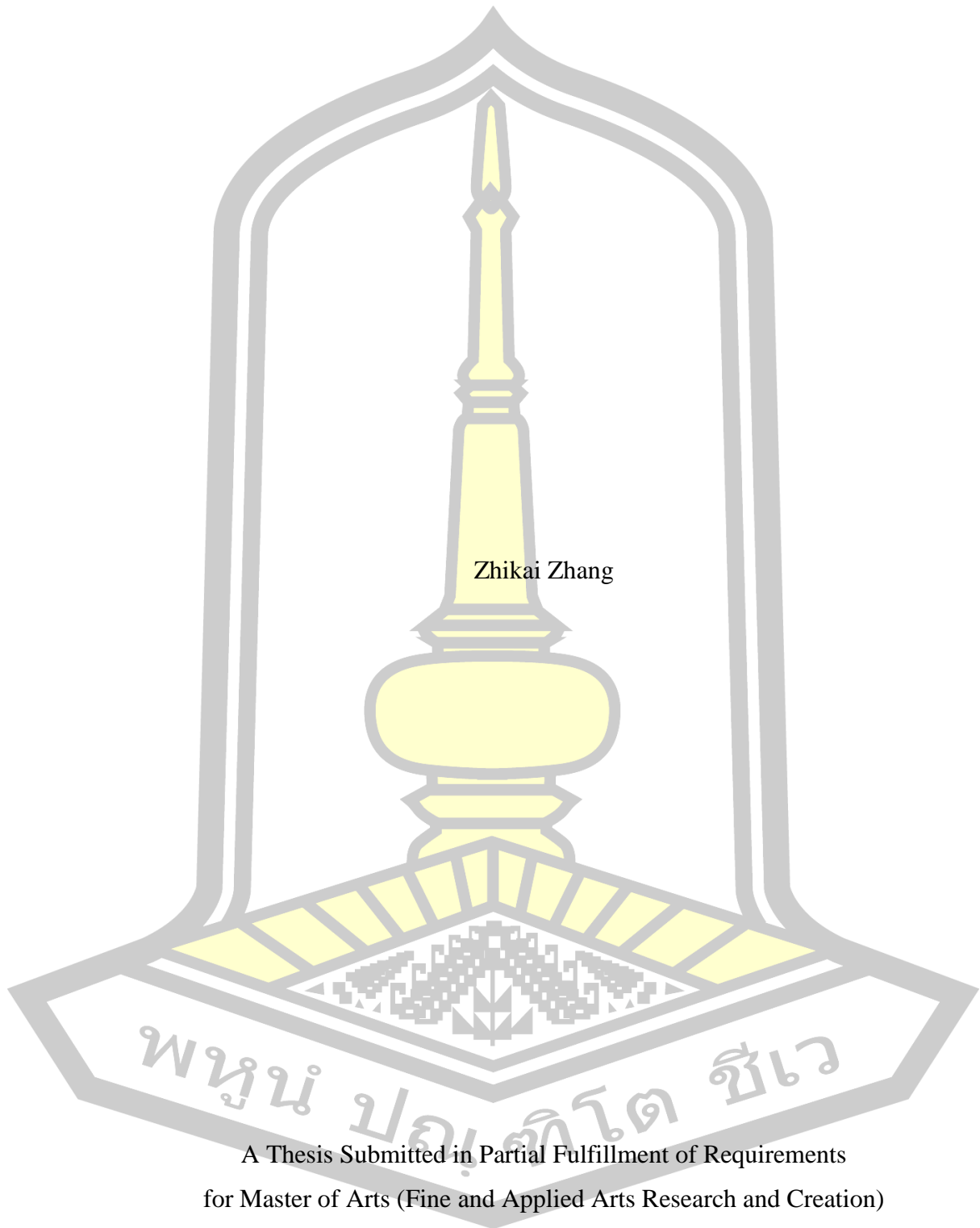

Zhikai Zhang

A Thesis Submitted in Partial Fulfillment of Requirements  
for Master of Arts (Fine and Applied Arts Research and Creation)

December 2024

Copyright of Mahasarakham University



The examining committee has unanimously approved this Thesis, submitted by Mr. Zhikai Zhang , as a partial fulfillment of the requirements for the Master of Arts Fine and Applied Arts Research and Creation at Mahasarakham University

Examining Committee

Chairman

(Asst. Prof. Songwit Pimpakun ,  
Ph.D.)

Advisor

(Asst. Prof. Metta Sirisuk , Ph.D.)

Committee

(Assoc. Prof. Suebsiri Saelee ,  
Ph.D.)

Committee

( Yihan Ke , Ph.D.)

Mahasarakham University has granted approval to accept this Thesis as a partial fulfillment of the requirements for the Master of Arts Fine and Applied Arts Research and Creation

(Asst. Prof. Peera Phanlukthao , Ph.D.)  
Dean of Faculty of Fine - Applied Arts  
and Cultural Science

(Assoc. Prof. Krit Chaimoon , Ph.D.)  
Dean of Graduate School

มหาสารคาม

**TITLE** Bamboo Wine Set Design : Ancient Chinese Craft Intellectual  
Heritage to new design

**AUTHOR** Zhikai Zhang

**ADVISORS** Assistant Professor Metta Sirisuk , Ph.D.

**DEGREE** Master of Arts **MAJOR** Fine and Applied Arts  
Research and Creation

**UNIVERSITY** Mahasarakham **YEAR** 2024  
University

### ABSTRACT

Explore the application and inheritance of ancient Chinese craftsmanship knowledge in modern bamboo wine container design. Through in-depth research on ancient bamboo weaving techniques, Decorative arts and cultural connotations, we have found that traditional craftsmanship knowledge not only provides rich sources of inspiration for modern design, but also endows products with unique aesthetic value. The research results indicate that combining ancient craft knowledge with modern craft knowledge in design concepts can create a modern bamboo wine vessel that retains both traditional charm and flavor. Meanwhile, bamboo, as a renewable resource, has significant advantages in environmental protection and sustainability.

Keyword : Ancient Chinese, Set Design, Bamboo



## ACKNOWLEDGEMENTS

Explore the application and inheritance of ancient Chinese craftsmanship knowledge in modern bamboo wine container design. Through in-depth research on ancient bamboo weaving techniques, Decorative arts and cultural connotations, we have found that traditional craftsmanship knowledge not only provides rich sources of inspiration for modern design, but also endows products with unique aesthetic value. The research results indicate that combining ancient craft knowledge with modern craft knowledge in design concepts can create a modern bamboo wine vessel that retains both traditional charm and flavor. Meanwhile, bamboo, as a renewable resource, has significant advantages in environmental protection and sustainability.

Zhikai Zhang



## TABLE OF CONTENTS

	<b>Page</b>
ABSTRACT.....	D
ACKNOWLEDGEMENTS.....	E
TABLE OF CONTENTS.....	F
LIST OF TABLES.....	H
LIST OF FIGURES.....	I
CHAPTER I.....	1
INTRODUCTION.....	1
1. Background.....	1
1.2 Purpose of the Research.....	7
1.3 Hypothesis of the Research.....	7
1.4 Scope of the Research.....	8
1.5 Research Methods.....	9
1.6.Data Collection Tools.....	11
1.7.Literature Review.....	11
1.8.Conceptual Background.....	33
1.9.Benefits of Research.....	35
CHAPTER II.....	36
The current situation of bamboo wine packaging.....	36
2.1.Development of Chinese bamboo handicrafts.....	36
2.2.Current situation of bamboo wine packaging.....	45
CHAPTER III.....	47
The wisdom of local wine packaging production.....	47
3.1.Development of production.....	47
3.2 Production process.....	53
CHAPTER IV.....	59

Design and develop packaging for local smart bamboo wine .....	59
4.1 The production and design steps are as follows : .....	59
CHAPTER V .....	74
CONCLUSION.....	74
5.1 Conclusion .....	74
5.2.Discussion.....	77
5.3.Suggestions .....	83
REFERENCES .....	86
BIOGRAPHY .....	89

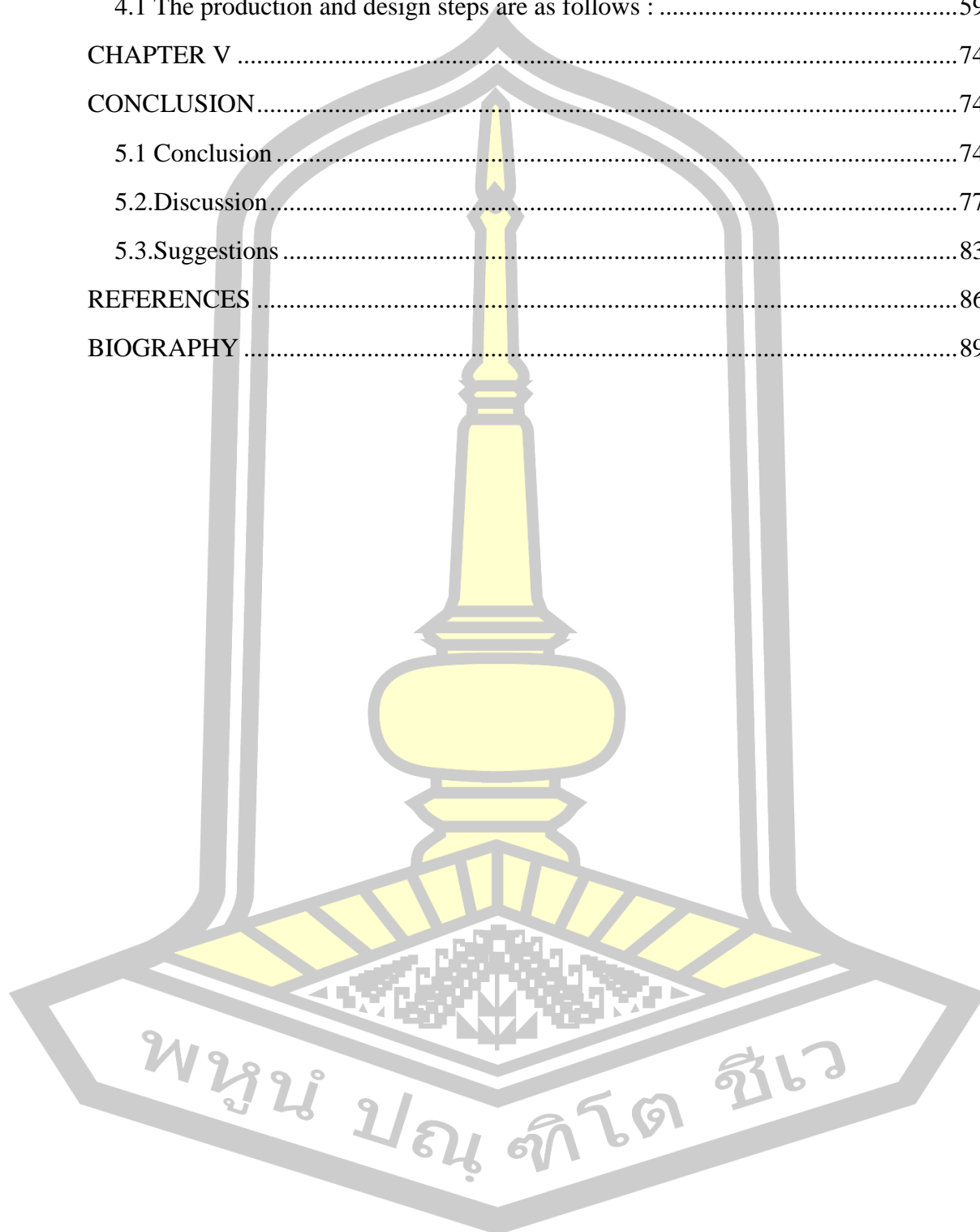

## LIST OF TABLES

Page

ไม่พบรายการสารบัญภาพ

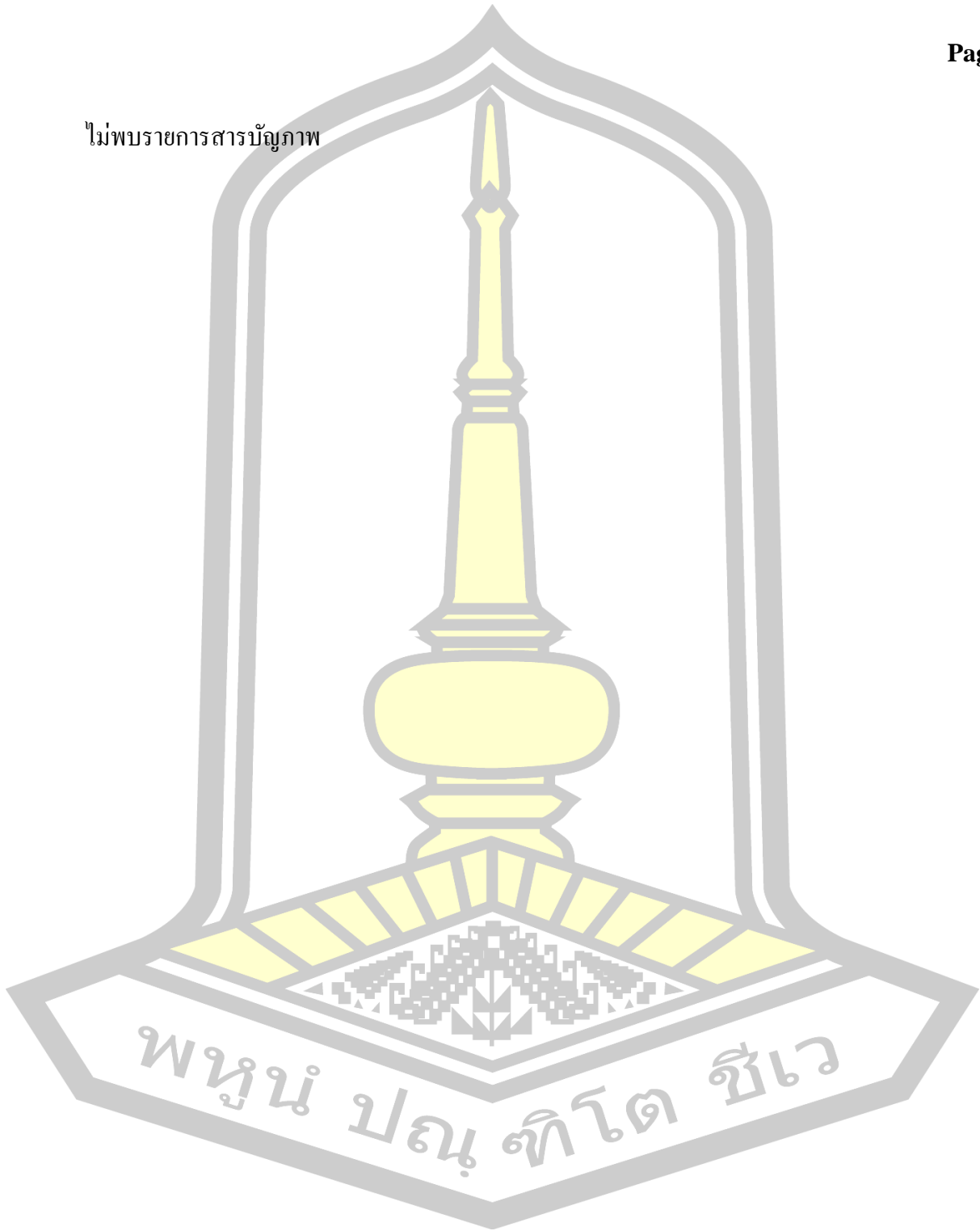

## LIST OF FIGURES

	<b>Page</b>
Figure 1 .....	33
Figure 2 .....	65
Figure 3 .....	66
Figure 4 .....	67
Figure 5 .....	67
Figure 6 .....	70
Figure 7 .....	70
Figure 8 .....	72
Figure 9 .....	72

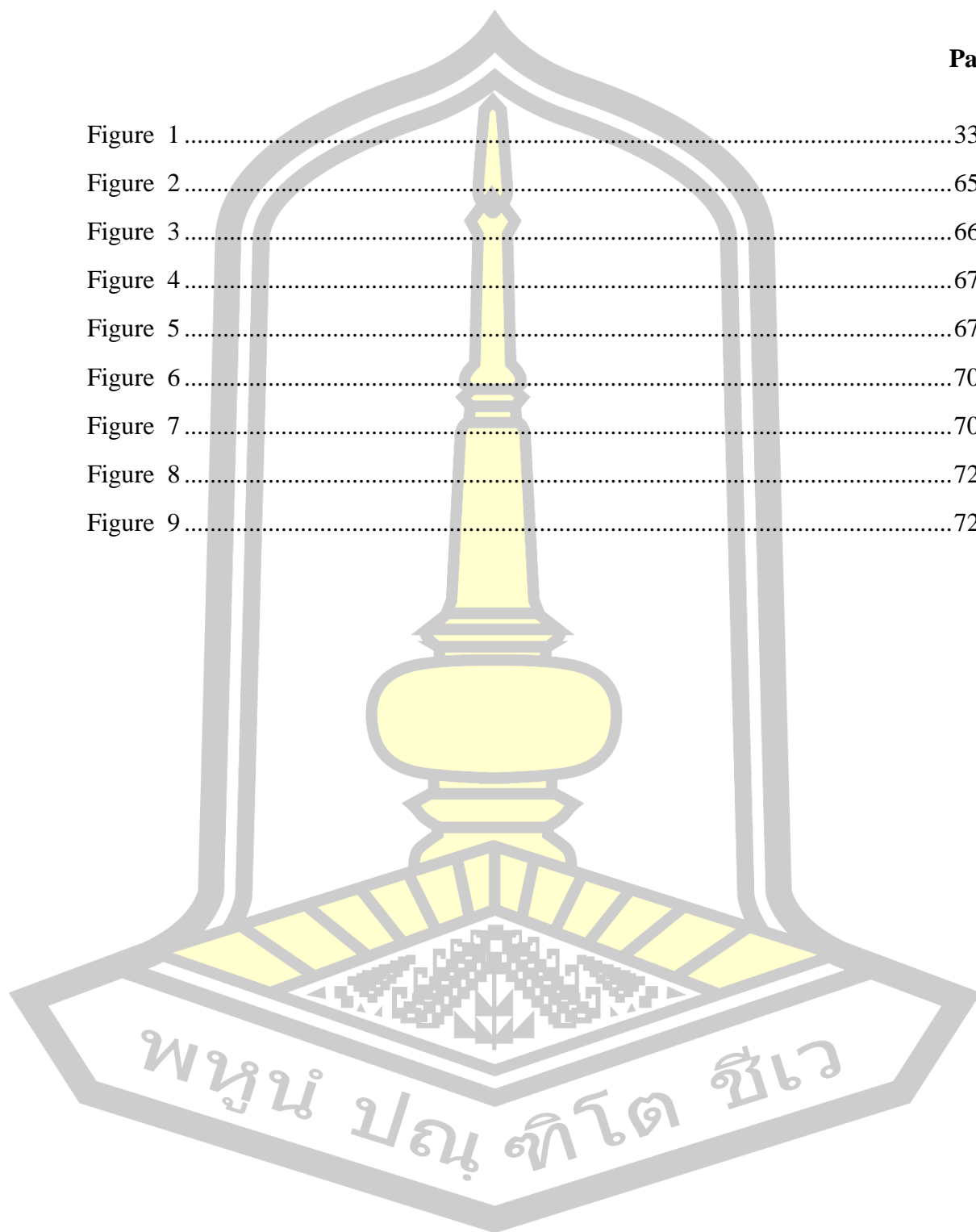

# CHAPTER I

## INTRODUCTION

### 1. Background

As a material with unique texture and ecological value, bamboo plays an important role in traditional Chinese culture. Its light, tough and natural properties make it ideal for making wine containers. Historically, bamboo wine containers have been loved by people for their natural beauty and practicality, reflecting the wisdom and aesthetics of ancient Chinese crafts.

It is necessary to have a deep understanding and research of Chinese traditional culture. This includes Chinese history, philosophy, art, literature and many other aspects. By understanding these aspects of knowledge, designers can better understand the essence and core values of traditional Chinese culture, and provide rich inspiration and materials for the design of bamboo wine containers.

In traditional culture, there are many representative and symbolic elements and symbols, such as dragon, phoenix, moire, bamboo weave texture and so on. Designers can extract the elements suitable for bamboo wine container design from these elements and symbols, and cleverly integrate them into the design. Through the use of these elements, the unique charm and spiritual connotation of traditional Chinese culture can be conveyed.

With the change of times, the traditional craft knowledge is facing the problems of inheritance and innovation. The design and research of bamboo wine container aims to combine the traditional craft knowledge of ancient China with the modern design concept to realize the integration of tradition and modernity. Through excavating and sorting out traditional craft knowledge, combining modern design techniques and craft technology, the design of bamboo wine container is innovated, so that it not only has historical and cultural heritage, but also meets modern aesthetic and practical needs. In the inheritance of wine culture, bamboo wine containers also play an important role.

With the change of times, the traditional craft knowledge is facing the problems of inheritance and innovation. The design and research of bamboo wine container aims to combine the traditional craft knowledge of ancient China with the modern design concept to realize the integration of tradition and modernity. Through excavating and sorting out traditional craft knowledge, combining modern design techniques and craft technology, the design of bamboo wine container is innovated, so that it not only has historical and cultural heritage, but also meets modern aesthetic and practical needs.

Chinese traditional culture emphasizes "both form and spirit", that is, the harmonious unity of form and artistic conception. In the design of bamboo wine containers, designers can create a kind of artistic conception and atmosphere with the characteristics of Chinese traditional culture through the clever treatment of the form and the use of decorative techniques. This artistic conception and atmosphere can

trigger the resonance and association of consumers, so that they can feel the charm of traditional Chinese culture more deeply.

Chinese traditional craft is famous for its exquisite skills and unique aesthetic value. In the design of bamboo wine containers, designers can learn from and inherit the spirit and skills of traditional crafts, such as bamboo weaving, bamboo carving, etc. Through the study and application of these traditional crafts, we can not only make the products have unique aesthetic value, but also show the exquisite skills of Chinese artisans and their reverence for traditional culture.

Traditional Chinese culture emphasizes the harmonious coexistence between man and nature and the interaction and connection between man and the environment. In the design of bamboo wine containers, designers can emphasize the integration of nature and humanity, coordinate the product with the natural environment by using natural materials and learning from the natural landscape, and reflect the Chinese people's reverence and gratitude for nature and life.

The traditional design concept emphasizes the realm of "harmony between nature and man" and "forgetting both things and myself", focusing on the harmonious coexistence between man and nature. In the design of bamboo wine containers, we can learn from these traditional ideas, emphasize the unity of product practicality and aesthetic, pursue simple and natural design style, and reflect the wisdom and charm of traditional culture.

As an environmentally friendly and natural packaging material, bamboo wine containers have been gradually recognized in the wine market. However, high production costs limit its popularity and promotion. This paper aims to analyze the main factors affecting the production cost of bamboo wine containers, and put forward some suggestions and methods to reduce the cost, in order to promote the sustainable development of the industry.

#### Characteristics and application fields of bamboo wine containers

Bamboo wine containers occupy a place in the wine market because of their nature, environmental protection and unique cultural connotation. However, high production costs make its price relatively high, thus limiting its market share expansion.

#### **Analysis of influencing factors of production cost**

The main factors affecting the production cost of bamboo wine containers include material, process and equipment. First of all, bamboo collection, processing and transportation costs directly affect the cost of production. Secondly, the complexity of the production process, the technical level of the workers and the advanced level of the equipment will also have an important impact on the production cost.

#### 1.1.Suggestions and methods to reduce production cost

##### 1.1.1.Optimized process flow

Simplifying the production process and reducing unnecessary intermediate links can reduce the production cost. For example, by improving the processing methods of bamboo, the utilization rate of bamboo is increased and waste is reduced.

#### 1.1.2.Improve material utilization

It is an effective way to reduce the production cost to make reasonable use of bamboo and improve the utilization rate of materials. For example, optimizing the way bamboo is cut reduces the production of scraps.

#### 1.1.3.Adopt advanced equipment and technology

The introduction of advanced production equipment and technology to improve production efficiency and product quality, thereby reducing the production cost per unit of product. For example, the introduction of automated production lines to reduce manual operation and reduce labor costs.

#### 1.1.4.The market impact of reducing production costs. Enhance market competitiveness

Reducing production costs can make bamboo wine containers more competitive in price, thereby expanding market share and improving corporate profitability.

#### 1.1.5.Ensure product quality

While reducing costs is the goal, product quality must not be sacrificed. Optimizing the process and improving the accuracy of the equipment can reduce the cost while ensuring the quality of the product.

#### 1.1.6.Strengthen environmental protection

By reducing production costs, enterprises can invest more resources in environmental technology innovation and sustainable development, and further strengthen the environmental protection concept of bamboo wine containers.

In modern society, with the improvement of people's quality of life, higher requirements have been put forward for the design of wine containers. Although the traditional bamboo wine containers have a unique charm, they combine traditional craft knowledge with modern design concepts.

As a renewable resource, bamboo has a short growth cycle and a small impact on the environment, which meets the requirements of sustainable development. In the design and research of bamboo wine containers, the integration of environmental protection concepts is not only helpful to promote the sustainable development of the design field, but also in line with the environmental protection needs of modern society. Research on bamboo wine container design not only helps to promote environmental protection and sustainable development in the design field, but also conforms to the current green development trend of society.

In modern society, with the increasing awareness of environmental protection, how to integrate the concept of environmental protection into product design has become the focus of designers. Bamboo wine container as a combination of traditional and modern products, its design not only reflects the unique aesthetic value, but also the concrete embodiment of environmental protection concept. This paper will discuss how to show environmental protection concept in bamboo wine container design from many aspects.

#### Sustainability and environmental benefits of bamboo wine containers

As a renewable resource, bamboo has the characteristics of rapid growth, recyclability, and low impact on soil and water resources, so bamboo wine containers have significant advantages in terms of sustainability. At the same time, the natural

texture and color of bamboo itself bring a unique texture and beauty to the product, making it environmentally friendly and elegant at the same time.

#### 1.1.7. Bamboo wine container design principles

When designing bamboo wine containers, the following principles need to be followed:

**Using renewable resources:** Bamboo is the main material to ensure the sustainability and environmental protection of the product.

**Maximize the use of natural materials:** minimize unnecessary processing and waste during the design process, and make full use of the natural form and characteristics of bamboo.

**Combined with modern design concept:** The use of modern design techniques to make bamboo wine containers not only have traditional charm, but also meet the modern aesthetic needs.



#### 1.1.8.Eco-friendly material choice: the charm of bamboo

Bamboo was chosen as the main material because of its unique ecological and physical properties. Bamboo's short growth cycle, rapid regeneration and low pressure on soil and water resources make it an ideal eco-friendly material. In addition, bamboo has excellent compression, bending and heat insulation properties, which is very suitable for making wine containers.

#### 1.1.9.Energy-saving manufacturing process

In the manufacturing process of bamboo wine containers, it is very important to adopt advanced energy-saving technology and equipment. For example, by optimizing production processes, updating energy-saving equipment, and reducing energy consumption, production costs can be reduced while reducing the burden on the environment.

#### 1.1.10.Efficient resource recycling

Waste or scrap bamboo wine containers can be recycled, through reprocessing or recycling, to achieve the recycling of resources. In addition, the integrated use of waste with other industries can be explored to create additional value and reduce waste.

#### 1.1.11.Good packaging and supply chain management

Moderate packaging of products to avoid excessive packaging caused by waste of resources and environmental pollution. At the same time, optimize supply chain management, reduce logistics costs, and reduce carbon emissions during transportation.

#### 1.1.12.Cross-border cooperation and promotion

Advocate cross-border cooperation within the industry, integrate the superior resources of all parties, and jointly promote the development of bamboo wine container design to a more sustainable, friendly and socially responsible direction. Through cooperation, resources sharing, technological innovation and market expansion can be achieved, thus promoting the green development of the entire industry.

#### 1.1.13.Government policy support and consumption concept change

Government policy plays a key role in promoting the development of green products. By making relevant laws and regulations and supporting policies, the government can guide enterprises and consumers to pay more attention to environmental protection issues. At the same time, with the improvement of consumers' environmental awareness, their demand for green products is also increasing. This provides a good market opportunity for enterprises to develop and produce bamboo wine containers.

As a concrete embodiment of environmental protection concept, bamboo wine container design not only has unique aesthetic value, but also has important environmental protection significance. Through innovative design methods, the green concept is incorporated into bamboo wine containers, which can improve the contribution of enterprises in the field of environmental protection, while meeting the demand of consumers for green products. In the future, with the deepening of the concept of environmental protection and the continuous progress of technology, bamboo wine container design will usher in a broader development prospect.

The research background covers the uniqueness and cultural value of bamboo, the mining and inheritance of traditional craft knowledge, the innovation needs of modern design, and the integration of sustainable development and environmental protection concepts. This research will not only help to promote innovation and development in the field of design, but also help to protect and inherit traditional Chinese culture and art forms, while promoting the application of sustainable development and environmental protection concepts in the field of design



## 1.2 Purpose of the Research

- 1.The present situation of bamboo wine containers was studied
- 2.Learn about local bamboo wine container production
- 3.Design and develop local bamboo wine containers

## 1.3 Hypothesis of the Research

Research hypothesis 1: Bamboo wine container design can enhance the cultural value of modern design by integrating ancient Chinese craft knowledge

Hypothesis: In the design of modern bamboo wine containers, the cultural connotation and uniqueness of the design works can be enhanced by drawing on and applying the knowledge of ancient Chinese crafts, such as traditional bamboo weaving skills and carving art, so as to enhance its market value and competitiveness.

Research hypothesis 2: The design of bamboo wine container combined with ancient Chinese craft knowledge can meet the modern aesthetic and practical needs

Hypothesis: By cleverly combining the knowledge of ancient Chinese crafts with modern design concepts, a bamboo wine container with both traditional beauty and modern aesthetic and practical needs can be designed to meet the aesthetic pursuit of modern consumers for the integration of tradition and modernity.

Research hypothesis 3: Bamboo wine container design can be used as an important carrier to inherit and promote Chinese traditional culture

Hypothesis content: Through the specific design practice of bamboo wine container design, traditional Chinese culture can be effectively inherited and promoted, so that more people can understand and identify with traditional Chinese culture, and enhance cultural self-confidence and identity.

Research hypothesis 4: The combination of ancient Chinese craft knowledge and modern design concepts helps to promote innovation and development in the design field

Hypothesis: By combining the knowledge of ancient Chinese crafts with modern design concepts, the boundary between tradition and modernity can be broken, innovation and development in the design field can be promoted, and new vitality and inspiration can be injected into modern design.

These research hypotheses are based on a preliminary exploration of the possibility and potential of combining ancient Chinese craft knowledge with modern design concepts. Through the concrete research and practice verification, these hypotheses can be further tested and improved, and more explicit and specific guidance can be provided for the design of bamboo wine containers. At the same time, the verification of these hypotheses is also helpful to promote the innovation and development of the design field, and provide useful reference for the integration of traditional and modern design practice.

## 1.4 Scope of the Research

### 1.4.1 Research area

Guangxi Bamboo Can wine is produced in Maoershan National Nature Reserve, Guilin, Guangxi, 1500 altitude bamboo economic forest area is China's top ten bamboo production base, Maoer flavor liquor in bamboo after 3 to 6 months accompanied growth, the wine body into amber color, wine quality with fruit wine sweet and mild bamboo taste. More than 60 nutritional factors were produced by secondary fermentation of bamboo.

The rich bamboo resources and long tradition of bamboo weaving techniques in Guilin, Guangxi are integrated into modern design.

Bamboo is a treasure in the whole body, known as "green gold, the king of plants" in Southeast Asia, bamboo juice outstanding health care role, in the East is regarded as "God water". In our folk there are "eating, feeding, nourishing, curing, curing" saying.

### 1.4.2 Time

One section after another, thousands of schools save thousands of leaves. I do not blossom, do not flirt with bees and butterflies', just like the bamboo heart without distracted thoughts, willing to be indifferent, calm and calm character, from the 1990s that began to develop bamboo wine, in the spirit of 'anchor castle peak', devoted to research and development, after repeated trials, trial drinking, trial production, evaluation, adjustment.

In 2009, bamboo tube wine was finally successfully finalized and put on the market, and the resulting live bamboo wine has significantly increased the amino acid components in the wine, significantly reduced the harmful components such as methanol and heterol, and its taste, style, taste, color and material composition are different from white spirits, adding a new connotation of activation, ecology, cleanliness and deepening the quality of today's wine. Improve the comfort of drinking, the formation of a unique flavor of wine '.

### 1.4.3 Scope of Design

It involves the understanding of traditional craftsmanship, the integration of modern design concepts, Bamboo products occupy an important position in ancient Chinese culture, whether it is containers, furniture or daily necessities, all show the exquisite skills and profound cultural heritage of ancient craftsmen. The design of bamboo wine containers can draw inspiration from ancient modeling, structure, decoration and other elements, and combine traditional crafts with modern aesthetics.

The application of modern design concept in bamboo wine container design is also essential. Modern design focuses on the unity of functionality, practicality and aesthetics, but also emphasizes the concept of environmental protection and sustainability. When designing bamboo wine containers, we need to

take these modern needs into account and use modern design means and methods to create works that are both in line with modern aesthetics and have practical value.

1.4.4. In terms of design scope, it can be expanded from the following aspects:

**Modeling design:** Combined with the modeling characteristics of ancient bamboo products, we designed a bamboo wine container with a unique style. The lines, proportions and compositions of ancient artifacts can be borrowed to create works that are both traditional and modern.

**Structural design:** Using the natural properties and structural characteristics of bamboo, we designed a stable and beautiful bamboo wine container. For example, the toughness and elasticity of bamboo can be used to design innovative structural forms.

**Decorative design:** Decorative treatment on the surface of bamboo wine containers can increase its artistic value and appreciation.

## **1.5 Research Methods**

### **1.5.1 Population and Sample**

Adhere to the principle of combining ancient Chinese craft knowledge with modern design concepts, and pay special attention to cooperation with artisans. The craftsmen have rich experience and traditional skills, which not only ensure the realization of the design, but also give the work a unique handmade charm and cultural connotation.

The joint selection of high-quality bamboo as raw materials ensures the high quality of bamboo wine containers. In the treatment process, the bamboo is carefully polished and polished using traditional techniques and tools, so that its surface is smooth like a mirror and the texture is clearly visible. At the same time, according to the needs of the design, the bamboo is cut and polished to create the required shape and structure.

In structural design, I worked with artisans to discuss how to incorporate ancient craft knowledge into modern design. According to the needs of modern use, the structure has been optimized and improved to make it more in line with the modern use habits.

Decoration is an integral part of bamboo wine container design. Traditional techniques such as carving are used to integrate elements such as patterns and poetry. According to the design pattern, the use of exquisite skills to carve on the bamboo, so that the pattern is lifelike and full of artistic sense. These decorations not only enhance the aesthetic value of the wine container, but also reflect the charm of traditional culture.

Exquisite display of artisan skills is undoubtedly the heart and soul of the whole project. These skills are not only the inheritance of ancient Chinese craft knowledge, but also the perfect integration and innovation of modern design concepts.

From the beginning of the selection and treatment of bamboo, the craftsmen have shown their unique vision and deep skills. They will carefully select the most suitable bamboo for making wine containers based on the growth age, texture, color and other factors. Subsequently, through a series of processes such as peeling, grinding and drying, the bamboo is treated smooth and delicate, laying a solid foundation for subsequent processing and production.

In the structural design and production process, craftsmen use craft techniques to form a solid and hierarchical structure. With their rich experience and superb skills, they are able to accurately grasp every detail to ensure that the structure of the wine container is both beautiful and practical.

Focus on quality control and inspection throughout the production process. They strictly check every step of the production process to ensure that the quality of the wine container meets the requirements. At the same time, they will also carry out trial installation and trial of the finished product to check whether its sealing, usability and other performance is up to the standard.

Through the exquisite display of artisans' skills, and with their own talent and efforts, the artisans have perfectly combined traditional craftsmanship with modern design to create bamboo wine containers with unique styles and cultural connotations. Their skills are not only the inheritance and development of traditional culture, but also the innovation and expansion of modern design concepts.

It is necessary to select healthy and pest free bamboo from high-quality bamboo forests. It should have a solid texture and even texture to ensure that the produced wine container has enough durability and aesthetics. Cleaning and sterilization are two crucial steps that ensure the hygiene and safety of wine containers.

Cleaning the bamboo tube is an essential step. Due to the material and structural characteristics of bamboo tubes, dust, impurities or other stains may be attached to the surface and interior. Therefore, it must be thoroughly cleaned before use.

The external cleaning of the bamboo tube can be gently wiped with a soft brush or a damp cloth to remove dirt and dust on the surface. For difficult to remove stains, you can use a mild cleaning agent to clean, but be sure that the cleaning agent will not remain in the inside of the bamboo cylinder, so as not to affect the quality of the wine.

The interior cleaning of the bamboo tube, due to the relatively narrow space, may require some special tools, such as a long-handled brush or straw brush, to ensure that the internal stains and residues can be thoroughly removed. After cleaning, sterilization is equally important. Bamboo containers may be exposed to various bacteria during growth, processing and storage, so sterilization must be carried out to ensure the hygiene and safety of wine containers.

A common way to kill bacteria is to boil it with boiling water. Putting the cleaned bamboo tube into boiling water for a few minutes can effectively kill most of the bacteria. However, it should be noted that the boiling time should not be too long to avoid damage to the material of the bamboo tube.

In addition, the bamboo cans are also disinfected with disinfectants such as ultraviolet sterilizers or lime water. These disinfectants can effectively kill bacteria and do not cause damage to the material of the bamboo tube. However, it is also necessary to pay attention to the use method and dosage to avoid the adverse effects of residues on the wine.

## 1.6.Data Collection Tools

### 1.6.1.Fieldwork and data collection

1.6.1.1) Interview ; Formal interview, Informal interview, Focus group interview.

1.6.1.2) Observation ; Normal observation (or general observation),

1.6.2.Participatory observation.

1.6.3.Documentary data collection.

1.6.4.Tool or Equipment for data collection.

1.6.4.1) Motion picture (cameras, video recording equipment).

1.6.4.2) Voice record.

1.6.4.3) Field notebook.

## 1.7.Literature Review

### 1.7.1. Chinese bamboo handicrafts

Zhang Xiaokai(2021) Write a book about Bamboo creation History of Chinese bamboo ware and production technology

China is a country of bamboo civilization, with green bamboo riding. To protect a gentleman is like sparring and grinding. Sexi Protocol, Hexi String. A gentleman with bandits cannot be boiled in the end. Looking at Qi Ao, green bamboo and green. There is a gentleman who understands, has a clear and elegant ear, and can speak like a star. Se Xi Xi Xi, He Xi Lian Xi. A gentleman with bandits cannot be boiled in the end. Looking at the Qidian, the green bamboo is like a calculation. There is a gathering gentleman, like gold as tin, like jade as jade. Wide and chubby, heavy and heavy. Be good at teasing and not being cruel- In the Book of Songs, Wei Feng, Qi Dian, green bamboo is compared to an elegant gentleman, and bamboo is compared to virtue. The full text of the translation is: Look at the winding banks of the Qi River, with green bamboo forests connected in patches. Mr. Gao is a gentleman, with more exquisite knowledge and skills, and better moral character. With a solemn demeanor and broad mindedness, he holds a prominent and prestigious position. An elegant gentleman is a true gentleman, who never forgets his heart at first sight. Look at the winding banks of the Qi River, with green bamboo fluttering gracefully. The elegant gentleman is a true gentleman, with beautiful and beautiful jade hanging in his ears, and a gemstone hat shining like a star. With a solemn demeanor and a broad mind, one's status is more prominent and majestic. An elegant gentleman is a true gentleman, who never forgets his heart at first sight. Look at the winding banks of the Qi River, with lush green bamboo all over. The elegant gentleman is a true gentleman, as strong as a bronze vessel, and as solemn as a jade ritual vessel. Broad and magnanimous, leaning on the ears of the car to drive forward. Humorous and witty speech, no one complains when joking. The Book of Songs is an important ancient Chinese classic that records the customs of the Shang and Zhou dynasties, and the civilization of bamboo can be seen early in China. To be precise, the history of ancient Chinese people using bamboo tools can be traced back to prehistoric times, with physical evidence of unearthed bamboo tools dating back approximately 7400-6700 years. In the long history of about 7000 years of bamboo ware, from bamboo weaving ware in the Neolithic Age, mining bamboo ware in the Shang Dynasty, mining and fishing bamboo ware in the Western Zhou Dynasty,

colored bamboo ware in the Spring and Autumn Period and the Warring States Period, colored dragon shaped spoon in Mawangdui of the Han Dynasty, bamboo ware system in Shuowen Jiezi, bamboo ancient records and seven sages in the bamboo forest in the Wei, Jin, Southern and Northern Dynasties, bamboo chairs and foot eight in the Tang Dynasty, to bamboo flower baskets and tea fighting bamboo ware in the Song Dynasty, large bamboo mats and Loong Boat and farm implements in the Yuan Dynasty, Jiading bamboo carvings in the Ming Dynasty, bamboo baskets in Jiangsu and Zhejiang in the Qing Dynasty, and all kinds of bamboo ware today, China It deserves to be called "the country of bamboo civilization".

Sum up: As productivity continues to improve, broadly speaking, humans have gone through three distinct stages of design patterns.

#### Manual - Manual mode

In agricultural society, people most commonly use biological forces or natural forces, such as human, animal, wind, water, and so on. Creation activities based on manual manufacturing are mainly used in family daily life. Skills are passed on through the one-to-one teaching mode of master and apprentice. Hand-making is the main feature of human creation in this stage, and it is also the stage of human continuous use for the longest time.

In the thousands of years of bamboo development in China, all the bamboo utensils produced were made in manual mode. Therefore, the bamboo wares in the history of China, including those currently being used in some rural and remote areas of China, are all made by craftsmen - bamboo craftsmen in accordance with the manual production mode. Handmade bamboo wares occupy most of the varieties and history of Chinese bamboo wares.

#### Automatic - Industrial mode

With the advent of the Industrial Revolution, productivity developed rapidly. In the industrial model, the basis of design is first machine production, and only the design that can adapt to machine production can be adopted. The ability to use machines for production has become the standard to measure the merits of all designs. Traditional handwork is completely degraded and even disappeared because it does not meet the standards of industrial production modes. The traditional handicraft of making bamboo ware is declining in the industrial society, and there are fewer and fewer craftsmen.

Joseph Terence Montgomery Needham (1954) Write a book about Science and Civilization in China

"East Asia is often referred to as the bamboo civilization. There is evidence that bamboo was known to the Chinese during the Shang Dynasty for a variety of uses, one of which was for writing. These scripts are roughly the same as those preserved to this day in the early Han Dynasty, and after writing on bamboo or wood slices, they are woven together with two strings.

Sum up: We can know from the oracle image of the word "book" that this word is used to describe the shape of the book. Canon

Quote: Bamboo carving of Chinese traditional Arts and Crafts China is the first country to use bamboo products in the world, so bamboo carving has a long history in our country. Bamboo carving, also known as bamboo carving, is to carve a variety of decorative patterns and characters on bamboo objects, or to carve a variety of furnishings with bamboo roots.

Record: Bamboo carving has become an art, since the six dynasties, until the Tang Dynasty gradually became known and loved by people. The development of bamboo carving flourished in the Ming and Qing dynasties, and the exquisite carving skills surpassed the previous generations and became unique in the history of Chinese arts and crafts. In the early period of bamboo carving, the decoration of palace, figures, landscapes, flowers and birds was usually engraved on the objects. Moreover, there are few bamboo carvings in the world, and most of them are handed down from the Ming and Qing dynasties. The bamboo carving products of the Ming and Qing dynasties, the exquisite carving skills, have already surpassed the previous generations. The bamboo carving style of Ming Dynasty is mostly simple and thick, with full composition. The knife is deep, and the line steel is strong, and the pattern is covered with the body. The bamboo carvings of the early Qing Dynasty have the legacy of the Ming Dynasty, but the expression techniques are more rich and diverse, and the techniques of shallow carving and shallow relief are used simultaneously. Some of the fragrant bamboo carving works are simple and simple, and some are fine, dense and changeable. The main methods of carving are Yin line, Yang engraving, round carving, transparent carving, deep and shallow relief or high relief. The art of bamboo carving in China has a long history, and our academic and archaeological circles have always believed that long before the invention of paper, ink and ink, ancestors had learned to use knives to carve characters on pillars to remember things. This most primitive bamboo carving should precede oracle bone inscriptions. Because the oracle bone script already has the three elements of calligraphy art, and the so-called bamboo engraving, the initial engraving is only symbols. In ancient times, bamboo did not grow in the central plains and northern areas of China, so animal bones were used to write, and bamboo was abundant in the south, so symbols or characters were engraved on bamboo. But bamboo tubes are harder to preserve than animal bones. Therefore, after a long time, today we still have the good fortune to see the oracle bones relics of the Yin and Shang dynasties, but it is difficult to see the bamboo carvings of that time again.

However, according to the records in ancient literature, the source of Chinese bamboo carving art appeared as early as before the Shang Dynasty, which is beyond doubt. In addition, in ancient times, China has begun to use bamboo to manufacture production and living utensils. Out of the nature of the love of beauty, the decoration on the bamboo products is no different from the carved jade, stone, bone and wood. Therefore, it is not surprising to find carved bamboo ware in the ruins of primitive society. However, bamboo is fragile and difficult to preserve until now.

As a formal work, bamboo carving had been formed in the Western Zhou Dynasty. According to the Han Dynasty Dai Sheng "Etiquette · Jade Zao" records, the fluorene (also known as hand plate) held in the hands of the Western Zhou Junchen Dynasty meeting, some are made of bamboo, "where there is finger painting in front of the king, use fluorene." The book is written in fluorene." Only the official position is different, the material of fluorene is also different, "the son of heaven to

ball jade, the vassal to elephant (tooth), the doctor to fish beard Wenzhu, bamboo, wooden elephant can also". All the fluorene held by the literati are made of bamboo narrow boards, and this fluorene is engraved with some patterns. Although it is not yet a kind of handicraft, it reflects that people in the pre-Qin period have attached importance to the use of bamboo, and can cut or carve some simple finished products. And fluorene appeared almost simultaneously with bamboo slips. In archeological excavations, bamboo slips with such terms and characters have been found, such as "Sun Tzu's Art of War" and bamboo slips with medical prescriptions. In addition, bamboo fans, bamboo pen holders, bamboo gun poles, bamboo baskets, bamboo MATS, bamboo boxes, etc., also have everything. During the Warring States Period, lacquer ware flourished and the art of lacquer carving flourished. A considerable part of the lacquer body is made of bamboo pieces or accumulated bamboo, influenced by the art of lacquer carving, and later the production of bamboo itself also has an artistic tendency. The animal hoof-like bamboo lacquer box with lid unearthed in Hubei province is the product of this artistic tendency. It is first carved into a round box with a bracket like animal hoofs, and then painted. This carved bamboo box is a precious material for us to study the history of bamboo carving today. Bamboo carving in the Han and Tang dynasties, the earliest artifact seen at present, is a painted bamboo spoon carved with dragon pattern from the West Han Tomb in Mawangdui, Changsha, Hunan Province. This relief dragon pattern lacquer bamboo spoon is 65 cm long. It is made of bamboo and is decorated with black and red paint. A section near the top of the spoon handle is red, embossed with a black dragon, the image is vivid and simple. By the Jin Dynasty, bamboo pen holders appeared. According to ancient records, the bamboo pen holder used by Wang Xianzhi, a great calligrapher in the Eastern Jin Dynasty, was very delicate. Wang Xianzhi's pen holder, shaped like a bell - a round pot used to hold wine in ancient times, the surface of the bamboo ware has markings, like fur, Wang Xianzhi called it "Qiu clock", there is a certain reason, but this also reflects the bamboo pen holder made at that time, there is not yet a common artificial carving process. During the Southern and Northern Dynasties, according to the Biography of Ming Sangshao, the Book of Southern Qi, Xiao Daocheng, Emperor of Qi, gave Ming Sangshao, a great hermit at that time, a "Ruyi bamboo shoots sheaths" carved from bamboo roots. Northern Zhou Dynasty writer Gengxin "Fengbao Zhaowanghui wine" poem, "wild donkey leaves, mountain cup holding bamboo roots", also mentioned the wine glass carved from bamboo roots. It shows that the art of root carving appeared in the Southern and Northern Dynasties. The art of bamboo carving began in the Tang Dynasty, the most famous of which is the Shakuhachi bamboo engraved with the pattern of flowers and birds. Shakuhachi is a vertical wind instrument. It gets its name because the tube is about one foot eight inches long. The bamboo Shakuhachi of the Tang Dynasty in Japan is 43.6 cm long, with a mouthpiece diameter of 2.32 cm and three sections covered with patterns. There are 5 pressure holes on the front and 1 on the back. This shakuhachi, using the method of keeping green, shallow carving of Yin, pressure hole around and above the section, there are patterns. The images of beautiful women, trees, flowers, birds and butterflies are distributed on the tube, and the portrayal is extremely exquisite, with the style of the Tang Dynasty. According to Guo Ruoxu's "Picture Seeing and reading" records, the Tang Dynasty Dezhou governor Wang Yi family has a brush, bamboo pen tube "slightly thicker than the common pen tube, half an inch out of each

end, the middle engraved military line a auxiliary, horse hair, pavilion cloud water, all excellent; Every moment of "military line" poem two sentences, such as... Before the court Qi tree has been able to climb, the outer sign of people is not also "is also, it seems not human work, its painting trace if powder description, Xiangming can argue, cloud with rat teeth carving, so there are... Wang's pen tube record "Body type Han Tui's record painting". From this we can see that bamboo carving in the Han and Tang dynasties, in the entire history of bamboo carving, is still in the initial stage of art, it is characterized by attention to the external shape, therefore, the root carving was produced at that time, but the carving of the surface decoration is basically a single expression technique - line engraving.

Xu Mao-qi Cao Jie(2014) Write a book about A brief discussion on the design and innovation of bamboo weaving products

From function to aesthetic bamboo weaving technology originated in China, the history can be traced back to the beginning of the Neolithic Age. According to archaeological data, after people settled down, in order to solve the problem of food and water storage, they began to use plant branches to weave utensils. In the middle of the 20th century, bamboo weaving technology was classified into the arts and crafts industry and entered the art category, and craft masters began to seek fine and fine, seek truth and rhyme, and their skills reached the point of pure green as fire, and sometimes the fine of the bamboo wire made people feel that it was not the bamboo material.

Due to the influence of Western thought, Japanese bamboo weaving art is bold and innovative. It likes to use non-traditional weaving methods, such as rough weaving and parallel weaving, to boldly show the unique natural characteristics of bamboo and make the shape clean and beautiful. Nakatomi Ichiki, a master of modern bamboo art in Japan, makes innovations in the shape of living utensils or pure works of art, trying to express the simplicity of bamboo, whether placing objects or pure appreciation, its artistic and aesthetic characteristics are very strong. Process innovation: From bamboo to bamboo woven products, need to go through many processes. Bamboo and bamboo strips need to go through the roll section, bamboo, start, open, split, with the mouth split, split wire, draw, scrape the nine steps. In the past, these were done by hand, laborious. Now the use of mechanization can make part of the process can be simplified, such as the existing knotting machine, bamboo knitting machine and greatly improve the production efficiency. The author visited a knitting workshop near Qingning Bridge in Wuxi, where the bamboo woven products are basically some daily necessities, and some of its processes are completed by machinery, but the machinery can only complete part of it, and it still needs the skilled skills of the master. In addition, bamboo strips need to be bleached, carbonized, smoked or chemical reagents to change the color, as well as anti-mold and anti-moth treatment to make up for the shortcomings of the bamboo itself. Innovation of techniques: Bamboo weaving masters have devoted themselves to research and constantly create new weaving techniques. Different from traditional bamboo weaving techniques such as cross weaving, twist weaving, prism weaving and flower star weaving, modern weaving techniques have a sense of The Times. Such as Taiwan bamboo weaving commonly used random weaving method, first in

the weaving of the body to do a good job of the basic structure, and then use the irregular insertion of bamboo pieces to enrich the basic body.

Sum up: Bamboo weaving craft products are the survival of people in some areas. In areas rich in bamboo resources, a wide variety of bamboo woven supplies are widely used in life and production, permeating people's clothing, food, housing and transportation. Due to the low price of materials, mainly rely on the skills of artists to bring certain economic benefits, exported overseas, led to the economic development of the entire region. Some bamboo weaving masters spend years or even decades elaborating a piece of art, reflecting its economic value from its collectibility and appreciation. Bamboo weaving is one of the traditional Chinese crafts. With a history of thousands of years, it plays an important role in the stage of Chinese history. In folk life, the production of bamboo weaving technology not only solved the basic needs of people's lives, but also enriched their spiritual level. For example, in the Lantern Festival, artists use bamboo strips as a skeleton, supplemented by bamboo weaving as decoration to make lanterns; There are also bamboo horse shows, in which the "horse's head" and "horse's tail" woven from bamboo are worn in front and behind the actors for performance. In the aspect of technological development, bamboo weaving technology plays an important role in the production of pottery. The patterns of "mat pattern" and "basket pattern" on pottery are also developed from bamboo weaving patterns. In terms of cultural exchange, bamboo weaving crafts are the best goods of cultural exchange between China and foreign countries, and make contributions to the country. Ecological value bamboo woven products, the use of bamboo materials, taken from nature, used in nature, return to nature, no burden on the environment, it is natural green products. For the environment, it produces little pollution in the process of production, consumption and waste, which is consistent with the policy of "sustainable development" and rejects pollution at the source.

Ci Hai

Record: "Bamboo curtain painting, the art of adding pictures on the curtain woven with fine bamboo silk, produced in Liangshan County, Sichuan Province (now Liangping District, Chongqing City)." (Lu Fei kui P200)

Sum up: The production of Liangping bamboo curtain has a history of more than 1,000 years. According to historical records, as early as the Northern Song Dynasty, it was listed as a royal tribute and won worldwide fame, known as "the first curtain under heaven".

พหุคูณ ปณฺ ทิโต ชีเว

## Annals of Liangping County

It can be seen that the production history of the bamboo curtain that was once dedicated to the emperor as "tribute brocade" was earlier than that of the Song Dynasty. During the reign of Guangxu, painted curtains were developed. This kind of curtains were made of smooth and slender bamboo as weft and silk as warp. Chinese paintings such as landscapes and figures were painted on the format of the curtains to become exquisite wall decorations and curtains. (Issue 3,2016)

Mu Rongbing, Ning Shaoqiang (2011) Write a book about Market development and redesign strategy of traditional bamboo handicrafts in Guangxi

Record: In the past, due to the poor transportation in Guangxi, which is located in the remote southwest, people relied on manual manufacturing for most of their daily necessities. Many local daily necessities, including handicrafts, are made of bamboo, which is abundant in the local area, so we have accumulated a lot of experience in the production of bamboo products. With the development of economy, a large number of industrial daily necessities entered the life of Guangxi people, bamboo daily necessities began to be gradually replaced, losing the practical value, and traditional bamboo handicrafts are also on the verge of desperation. With the development of tourism, Guangxi, which is rich in natural resources, has become a tourist attraction, and many tourist attractions have been developed one after another. The development of tourism has led to the development of many surrounding industries. The rise of the tourist souvenir market has found a breakthrough point for the traditional bamboo handicrafts. However, although the tourist souvenir market is huge, it is a casual consumer goods, which has caused great restrictions on the production and sale of traditional bamboo handicrafts. Traditional bamboo handicrafts are facing the double test of market development and design renewal. Due to the particularity of handicrafts industry, many operators of bamboo handicrafts are skilled craftsmen.

Sum up: They have not learned marketing and lack of marketing awareness. Most of them rely on the pull of tourism in product sales, and adopt peddling and consignment, without forming systematic marketing channels. The product lacks publicity. This is easy to find, in newspapers, magazines, television, websites on the Guangxi bamboo crafts publicity and display. In the production of products, many manufacturers do not understand the needs of customers in the case of repeated production according to the old style, do not understand the market research, lack of innovation and design awareness. The lack of competitiveness of products leads many operators to carry out vicious competition in the way of low quality and low price.

Books - Mountain:

Bamboo carving records: Absorbs the form language of modern plastic arts from many aspects such as material, technique and style, and changes the inherent mode of traditional bamboo carving, and its works are refreshing. (Akihito 2019 P10)

Sum up: This kind of bamboo carving works, which are close to life and express life, break through the inherent theme and modeling style of traditional bamboo carving, and represent the innovative development of contemporary bamboo

craft in artistic concept and theme. This hyper-realistic expression technique can not only open a gap with traditional bamboo carving, but also can be understood and appreciated by foreign audiences, which is conducive to the overseas spread of bamboo craft.

Wang Xiaoge, Liu Jun (2020) Write Article About Cultural assignment and value reconstruction of contemporary bamboo craft:

Bamboo craft is not only a traditional handicraft, but also the carrier of traditional bamboo culture. In recent years, under the promotion of modern science and technology and environmental protection concepts, natural bamboo has been processed into high-density, high-strength, non-perishable artificial bamboo boards, which are convenient for mechanical processing and mass production, and gradually become a substitute for wood.

Sum up: Traditional handicraft is the starting point of human material creation and the source of creative wisdom, but also the basis of modern civilization and modern design. After entering the era of large-scale industrial production, handicraft creation highlights new value characteristics with its unique single-piece handmade way and artistic quality.

Bamboo technology is widely used, especially in China's traditional agriculture, forestry, fishing, tea and other industries, which often use bamboo production tools; In the daily life of the vast rural areas, it is still customary to use bamboo furniture and bamboo kitchen utensils. However, this kind of bamboo is mainly to meet the practical function, the price is also relatively low, folk bamboo craftsmen will customize some special shape of bamboo according to customer requirements, this kind of bamboo still plays an indispensable role in contemporary production and life.

Dai Yanling (2020) Write Article About Analysis on the artistic characteristics of bamboo weaving in Shidong town, Suining:

Apply: The basic techniques are mainly based on the warp and weft lines for preparation & in the form of preparation, can be divided into round surface preparation, twisted wire preparation, decorative preparation, etc., but the most commonly used or decorative preparation, it is generally used in a certain part of the product, to make it more delicate and beautiful, there are a variety of techniques such as threading, threading, elastic, and inserting tendons & threading is generally on the basis of loose weaving. (Selected from the application paragraph of the article)

Sum up: Interlace the strips to form a wide variety of irregular geometric patterns, while threading is still on the basis of triangular eyes and hexagonal eyes and then parallel interlace with thin strips in each mesh to form a more fine pattern & flaking is more fine processing on the basis of the previous process. It is mainly the use of wide strips regularly twisted into a variety of petal-like shapes, and then configured into bamboo woven products, so that bamboo woven products more delicate, more three-dimensional sense & inserted ribs mainly play a strengthening role, generally using thickness, width and narrowness

CAI Yushuo, Huang Qingqing, Zhu Weijun (2021) Write Article About Bamboo weaving is regarded as the intangible cultural heritage of Henan Province

According to the genealogy records of the inheritors of Luoning Bamboo weaving, the inheritance of Luoning bamboo weaving started from the first generation of inheritors Zhang Zhendong in the 1830s, which has a history of more than 190 years. Teaching both master and apprentice and father and son are the most traditional ways of inheriting folk handicraft skills. However, nowadays, bamboo weaving skills have been difficult to attract the interest of the young generation, there are few young apprentices willing to take the initiative to learn the inheritance of bamboo weaving skills, coupled with the existing inheritors are generally high age, so whether it is passed down by family or teacher, bamboo weaving inheritance is facing the crisis of "no successor". For a long time, the dissemination of Luoning bamboo weaving has mainly relied on bamboo weaving artists to promote it in a small range of folk. In today's developed we-media, there are few documents and media that systematically introduce bamboo weaving techniques and culture, and the materials available for audiences to understand Luoning bamboo weaving are very limited. "People-oriented" is the purpose of inheriting intangible cultural heritage, and culture must return to the life of the masses after all. Therefore, how to use the we-media platform to enhance the popularity of Luoning bamboo knitting is a problem that must be solved. Secondly, the sales channels of Luoning bamboo weaving are usually customized, folk bamboo weaving veteran artists retail or entrusted to sell, this phenomenon reflects the relatively "passive" market attitude of the current bamboo weaving sales group, which largely limits the development space of bamboo weaving products, and it is urgent to build a new communication and sales system of Luoning bamboo weaving.

The fact that a traditional handicraft technology can be maintained, continued and recognized in the course of history means that there is a certain continuous and stable element in it, which depends on its own internal dynamics, rather than the idealized restoration of the past cultural ecology. Rural people's cultural ecology has given birth to intangible cultural heritage, which seems to be incompatible with modern industrial metropolis life. However, modern urban ecology is turning to "post-metropolis", which means cultural diversification, and intangible cultural heritage that can be passed on alive will have a greater development space. Based on this, the necessity of living inheritance of Luoning bamboo weaving is reflected in the following two aspects. First, compared with the batch products produced by the industrial assembly line, traditional handicrafts are based on the "people" themselves, based on the national spirit, national emotion and national culture. Because they are most closely related to the life of the people, they are also the most active and vital types in the intangible cultural heritage. In the contemporary society oriented by consumer demand, the innovation of Luoning bamboo woven products on the basis of the uniqueness and nationality of the original materials and processes is the premise of inheritance and development.

Second, the word "living state" contains the preservation and extension of folklore ecology, and its concept is protected in a spontaneous and conscious sense. There are two different forms of operation for the protection of intangible cultural heritage. One is record, storage and collection, that is, archival management and

research. The common ones are the establishment of museums and the use of words and images to record. The second is derivative, development and inheritance, that is, open active protection and development, so that it can grow again in a new form. Although museum-style heritage protection, which documents and preserves intangible cultural heritage, plays an irreplaceable role, people who have experienced the industrial age increasingly show their spiritual needs for "slow life" and "traditional handicraft" after entering the information age.

Sum up:How to make these traditional manual skills can still provide modern production and life services for people in the information age is an important basis for the inheritance and development of Luoning bamboo woven products. In the past, Luoning bamboo knitting is to provide users with convenient daily utensils, or with aesthetic, ornamental crafts, is the craftsmen's livelihood, but in contemporary society, on the basis of inheriting traditional functions, Luoning bamboo knitting has long evolved into the most collective memory characteristics of the folk life customs of Heluo culture cultural products. With the help of concept innovation, cultural innovation and technological innovation, this bamboo weaving product loaded with the emotion and cultural identity of the Central Plains people will certainly find a broader living space in the new era.

Wang Hao (2023) Write book About Research on inheritance, innovation and development of bamboo weaving skills of Dai nationality

In order to promote the innovative development of Dai bamboo weaving skills, it is necessary to strengthen design innovation and pay attention to innovative ideas and ideas. Through the excavation and innovation of traditional skills, Dai bamboo weaving works with a more contemporary and creative sense are created to attract more young people's participation and attention. Patterns and patterns are the main carriers of bamboo weaving art and culture. The common weaving patterns of Dai nationality bamboo weaving are generally geometric patterns, including cross pattern, turtle back pattern and Herr pattern, and rarely involve other content. Some patterns are also common in bamboo weaving in other regions and do not highlight Dai characteristics.

Sum up:It is necessary to enrich and upgrade the weaving pattern materials, such as adding the theme of tropical plants of the Dai people; Animal themes such as peacocks and elephants; Peacock dance, egret dance and other dance themes; Pagoda, temple, Dai bamboo building and other architectural themes, it is abstract treatment, transformed into bamboo weaving language, improve the recognition and cultural connotation, attract consumers.

#### 1.7.2.Chinese wine container

Li Shizhen (1578) Write book About Compendium of Materia Medica

Bamboo has "cool heart meridian, benefit the vitality, remove heat to slow the spleen, nourishing blood refreshing" magic diet health.

Sum up:The wine stored in the bamboo body, after the bamboo fermentation of the wine, the taste of natural fragrance, bamboo body as a container of wine from mouth to ear.

Nine arts bamboo wood

The preservation environment of bamboo wine has an important influence on its quality. First of all, bamboo wine should be stored in a cool, dry, well-ventilated place, avoid direct sunlight and high temperatures. This is because the sun and high temperature will cause the alcohol in bamboo wine to volatilize, affecting the taste and aroma of the wine. In addition, the humid environment may also lead to mold or deterioration of bamboo wine, so the storage environment should be kept dry.

Sum up: Although bamboo wine has a long shelf life, too long storage may lead to a decline in wine quality. Generally speaking, the appropriate storage time of bamboo wine is 1-2 years. During the storage process, the state of bamboo wine should be checked regularly. If the liquor is found to be discolored, cloudy or smelly, it should be treated in time or stopped drinking.



### Brewing; Critical quality control point

Firstly, the wine brewing process flow chart is established, and according to the flow chart, the harm analysis is carried out in each link of the wine brewing process, the key quality control points that may cause harm to the wine quality are identified, the impact of the key points on the wine quality is analyzed, and corresponding prevention and control measures are formulated.

Sum up: Through active control, all potential hazards that may harm the wine quality are ensured without deviation Elimination ensures the best quality of the final wine before causing an accident.

Zuo Kecheng, Yang Qiang, TONG Guoqiang, Le Xixuan, SHI Peng, Guan Ying (2009) Write Artic about Study on quality stability of liquor by storage environment and packing method

To explore the quality stability analysis of liquor under different storage environments, bottle materials and packaging forms and determine the key factors affecting the quality stability of liquor, so as to provide security for the shelf life. Methods: Different types of wine were stored in high temperature, light and other storage environment and different packaging capacity equipment

Sum up:Quality and packaging methods to conduct quality stability research, to investigate and evaluate its stability. Results and CONCLUSIONS: No matter ordinary wine or mixed wine, wine quality stability during shelf life is related to storage environment and packaging container, and the quality of wine in storage environment is mainly affected by light and temperature. On the packaging container, the stability of wine quality under the same light conditions has an inverse relationship with the light transmittance of the bottle.

### Base wine storage quality analysis report

The base wine maintains the following conditions during storage:

Temperature: The temperature of the storage room is stable in the range of 18-22 degrees Celsius without significant temperature fluctuations.

Humidity: The relative humidity is maintained between 65% and 75%, which is conducive to the stable storage of the base wine.

Light: Low light conditions are used in the storage room to avoid the influence of light on the base wine.

Sum up:Alcohol content analysis: By densitometry, the alcohol content of the base wine was determined to be 40% (vol/vol), which met the standard requirements.

PH value: The pH value of the base wine is 5.2, which is in the acidic range and meets the standard requirements.

Volatile acid content: The volatile acid content was measured at 0.2 g/l, which was within a reasonable range, indicating that the base wine was not over-oxidized during storage.

Phenolic content: The determination result of phenolic content was 0.4 g/l, which met the standard requirements, indicating that the base wine was in good condition.

### Discussion on the quality control of liquor

The current sensory evaluation method of liquor is the national standard "Liquor Analysis Method" (GB/T 10345-2007), which stipulates the environmental

requirements, personnel requirements, standard evaluation equipment and comments during sensory evaluation of liquor. The specific items of sensory evaluation are color, aroma, taste and style. By comparing the color evaluation criteria of different flavors, it is found that only rice flavor liquor puts forward the requirements of colorless, clear and transparent, no suspended matter and no precipitation, while other mainstream flavor liquor gives the requirements of colorless or yellowish, clear and transparent, no suspended matter and no precipitation. There are slight differences in color evaluation between them, which should be paid attention to. In terms of aroma, since there are many aroma components in liquor, different aroma components and the ratio of different components all determine the flavor type of liquor. For example, Luzhou-flavor liquor is described as having a complex aroma with strong ethyl caproate as the main body, while clean-flavor liquor is described as having ethyl acetate as the main aroma. According to this obvious feature, some fake famous liquor on the market can be simply screened. In the taste evaluation, the description of different flavor baijiu is slightly different, and the words are professional and accurate, for example, the description of Qingflavor baijiu is soft and harmonious, sweet and clean, and the aftertaste is long, and the description of Luzhou-flavor baijiu is mellow and harmonious, sweet and clean, and the aftertaste is long, and the two are only one word difference, and special attention should be paid to the description.

The "Determination of Ethanol Concentration in Food Safety National Standard Wine" standard implemented in March 2017 replaced the old standard, compared with the old and new methods, the new standard added density bottle method, gas chromatography and digital densitometer method, improved the alcohol determination of different categories of alcohol products, and provided more detection means. The alcohol meter method is generally used to determine the alcohol content of liquor. The equipment used in this method is simple and easy to operate, and it is widely used in the self-test and supervision inspection of liquor production.

Sum up: The method needs to pay attention to three points, first, the liquor sample needs to be distilled, especially some self-brewed liquor or workshop liquor, due to the imperfect distillation process, often lead to liquor is not clear and transparent, with a small amount of suspended matter that is not easy to see by the naked eye, only through distillation treatment to accurately determine the alcohol content. Second, it is necessary to control the temperature during the measurement process to ensure the accurate volume, that is, to maintain the liquid temperature of 20°C when the liquor sample is taken and the volume is fixed after distillation in order to accurately determine the alcohol content. Third, the alcohol meter directly measured after the need for temperature correction, different temperature alcohol meter degrees vary greatly, no temperature correction data will lead to a large error. The level of alcohol is the only index to determine the high liquor and the low liquor, the accurate determination of alcohol is helpful to the classification of liquor, to meet the needs of different consumers. (Wang Xin, Jin Rong, Liu, Yang Chuncheng, Qing, Wang Weiyang 2020)

How to store white wine will not run wine

Old wine is good to drink this is known to all lovers of alcohol, but the preservation of white wine is also important to check your wine collection first, and re-tighten the bottle cap. Many bottles of wine are loose when they leave the factory,

and the consequences of "running wine" after a few years can be imagined! This is the first thing you must do to prevent "running away".

Warm the wax in a metal container. When the wax has melted into a liquid, turn the bottle upside down and dip the cap directly into the container. The disadvantages of this approach are: if the wax temperature is too high, the plastic cap is easy to deform; In addition, if your wine leakage is very serious, the wine bottle has just poured over the wine leakage, the wax seal is not successful.

Apply the melted utility wax to the joint of the cap and the mouth of the bottle with a brush. The disadvantage of this approach is that it destroys the original condition of the bottle cap, especially the original protective film on the plastic cap is dipped into the wax, which is not easy to restore.

Wrap the bottle mouth carefully with plastic wrap, wrap with transparent tape, the position of the bottle mouth will stretch the tape tight, more laps, transparent tape with a characteristic, the longer the time, the more tightly wrapped itself, be sure not to forget to set aside a section of glue head, or it will be difficult to remove. However, the effect of this approach is slightly worse than that of sealing wax.

The best way is: first tighten the bottle cap, carefully wrap the bottle mouth with plastic wrap, wrap it tightly with transparent tape, and then seal the wax, of course, to avoid light preservation, the temperature is appropriate, and there is no limit to time. The container for liquor storage must be ceramic or glass, in short, it is good to be closed, the storage location and temperature are best underground, because the underground is an environment with little temperature change, basically maintain room temperature, and liquor is a volatile substance, so it will not volatilized much, mainly to maintain the original flavor of liquor, not deteriorated, which is also important. The storage time should generally be no less than three years, so that the taste of the wine is pure and the taste is particularly good.

Sum up: If want to preserve all the year round, the ideal environment for all the wine is constant temperature, preferably around 10-15 degrees, constant humidity, dark conditions, these are professional conditions of wine cellars or natural cellar caves.

But the conditions of spirits can be worse, such as being displayed in domestic conditions.

It's a little more stringent for the brewed wine, for the average consumer. It can be placed under the bed at home, where it is dark and safe from disturbance.

Seal and store in a cool place. Aged wine will decrease in strength and become viscous, but some people like this wine, not the quality of the decline. Alcohol is mainly lost through the gap in the bottle stopper, and in the past, the wine altar was sealed with mud

### **State Food and Drug Administration on further strengthening the quality of liquor**

In recent years, food safety supervision departments at all levels have been taking liquor as the focus of food safety supervision and management, constantly increasing supervision efforts, strengthening special rectification, and the overall quality of liquor products is stable and reliable. However, at present, there are still some quality and safety risks in the production of liquor, such as the lax management of liquor production permits in individual places, the use of food additives beyond the

scope, the use of liquid liquor or solid-liquid liquor as solid liquor, the pollution of phthalates in liquor (that is, "plasticizers", hereinafter referred to as plasticizers) and the production and sale of fake and shoddy liquor. In order to further improve the quality and safety guarantee ability of liquor production enterprises and the overall level of liquor quality and safety, food safety supervision departments at all levels should further strengthen the supervision and management of liquor quality and safety, constantly improve the long-term supervision mechanism, urge enterprises to effectively protect the quality and safety of liquor, and promote the sustainable and healthy development of the liquor industry. The relevant matters are hereby notified as follows: Strictly implement the main responsibility of liquor production enterprises, and ensure the quality and safety of liquor from the source

Organize production in strict accordance with laws and regulations, food safety standards and production licensing conditions. Enterprises shall organize production in strict accordance with the relevant provisions and conditions of the liquor production license to ensure that the production conditions continue to meet the provisions. In accordance with the premise of the relevant industrial policy, the production license renewal, change, cancellation, etc. It is not allowed to resell, rent or lend the liquor production license, or illegally transfer the production license in other forms. The revision of the liquor production license review rules has been started, and new issues such as the control of plasticizer indicators are clearly included in the review rules, from raw materials to the quality and safety control of the whole process of production, and more stringent requirements are put forward. After the revision and release of the review rules, enterprises must comply with the renewal of the production license at the expiration of its validity period and effectively control the pollution of plasticizers in liquor. Enterprises should effectively assume the main responsibility for food quality and safety, and do a good job in the pollution control of plasticizers in liquor: first, continue to investigate and rectify. According to the actual production of the enterprise, effectively investigate the cause, especially if the product is still detected after rectification, the source must be further identified, and the comprehensive and thorough rectification will not leave hidden dangers. Do not use pipes, containers, packages, etc. containing plasticizers in contact with alcohol. The second is to strictly close the raw materials. Enterprises that produce their own raw wine should strengthen the detection and control of plasticizers in raw and auxiliary materials; The plasticizer content of raw wine purchased by enterprises should be lower than the risk assessment value reported by the National Health and Family Planning Commission. Third, we will strictly supervise the production process. According to the whole process of production and processing, all the factors that may lead to the dissolution of plasticizer were evaluated, and timely measures were taken to control the pollution of plasticizer to liquor. Fourth, strengthen the control of finished products. Enterprises should ensure that the plasticizer in the finished product is lower than the risk assessment value notified by the National Health and Family Planning Commission. Once the plasticizer in the finished product is found to be higher than the risk assessment value, it shall not be allowed to leave the factory for sale, immediately stop production for rectification, continue to investigate the cause, and report to the local food regulatory authorities.

Sum up: Non-food raw materials shall not be used to produce liquor. Enterprises should effectively comply with the provisions of relevant laws and

regulations, strictly implement the raw materials procurement, production process safety management, storage management and other food safety management systems, to ensure that quality and safety problems can be traced. Strengthen the quality and safety management of raw materials and finished products in the storage and transportation links, and prohibit the use of non-food raw materials such as methanol and industrial alcohol to produce and process liquor. The edible alcohol purchased must meet the "Edible alcohol" (GB 10343-2008) standard, and it is strictly prohibited to use methanol as edible alcohol to produce and process liquor.

### 1.7.3.Principles of container design

The perfect combination of traditional materials and modern ideas

Bamboo packaging design pays attention to the integration of nature and humanity. As a product of nature, bamboo is closely related to human life. The form and texture of bamboo are often used in packaging design to coordinate products with the natural environment.

Bamboo packaging design emphasizes green environmental protection. Bamboo is a renewable resource that grows fast and is friendly to the environment. Bamboo packaging design makes full use of the characteristics of bamboo, adopts pollution-free technology and process, and reduces the impact on the environment.

Bamboo packaging design pays attention to the combination of creativity and art. Through the use of bamboo form and texture, the designer gives the packaging more artistic sense and creative elements, making it both practical and aesthetic value.

Bamboo products factory packaging specifications and packaging standards

The surface of bamboo products should be smooth, no knife marks, cracks, corners and smooth.

Sum up:The joint parts of bamboo products should be smooth and without cracking.

Bamboo products coating should be uniform, no particles, accumulation, flow hanging, paint leakage, peeling, cracks, bubbles, pinholes and other coating defects. Bamboo products should be normal color, no odor, no obvious scratches, cracks. Holes, and wood should be connected reliably, disassembly and convenient.

Zhong Shujia Sun Yutong(2017) Write Article about Bamboo culture in modern packaging design interpretation

Bamboo carving is a delicate job, in the Qing Dynasty, bamboo carving technology developed quite flourishing, artisans can be carved in the square between the beautiful flowers, birds, fish and insects. The expression of bamboo carving in addition to round carving and relief, stay green and so on. Liuqing is extremely particular about bamboo itself, which is also the most difficult carving technique. Skilled craftsmen skillfully use the relationship between bamboo skin and bamboo muscle to carve a vivid and colorful bamboo carving art. From the perspective of carving space, bamboo carving can be divided into two dimensions and three dimensions.

Literary symbols mainly include two aspects: one is the tangible people, things and objects in nature or social life that we can personally experience in literary works; The other is the intangible things in abstract literary images that are not easy to be

directly perceived by people, including thoughts, spirits, emotions, thinking and other profound experiences.

Sum up: Because of the unique natural characteristics of bamboo, such as hollow and jointed, it matches with the quality of traditional Chinese personality and forms a corresponding relationship, so bamboo is given a certain symbolic significance. Its symbolic meaning coincides with Confucianism in our country and becomes a kind of spiritual power. Ancient literati loved bamboo very much, which was probably inseparable from their social status and the political, economic and cultural background at that time. The character symbol of bamboo not only promoted the development of Chinese ancient poetry, painting and other cultural arts, but also cultivated the tenacious noble character and the national integrity of humility and fortitude of the Chinese nation.

Wu Jiahui, Wang Yunfang, Zhu Chenxi(2014) Write Article about On the application of traditional Chinese elements in the packaging design of bamboo chopsticks

Packaging design refers to the selection of appropriate packaging materials, the use of clever technological means, for the packaging of goods container structure modeling and packaging beautification decoration design. Based on the local culture, the traditional elements are integrated in the packaging design of bamboo chopsticks. In the market research, select the more competitive bamboo chopsticks brands in the market - "Liang Carpenter", "Tang Zong chopsticks" and "Wo Mu Tianxiang" to carry out brand analysis on their packaging, from which the advantages of unique and creative use of traditional elements are extracted for detailed consideration. "Good Carpenter" has a distinctive traditional elements of the unified brand color. Elegant and refined blue has the meaning of simple and elegant, to achieve the harmony of the ancients, giving people a bright feeling, it is easy to catch the eye of consumers, and stand out in many similar brands. Cultural concept: century-old inheritance, originality, cultural form using line drawing, virtual and real alternate, coordinated and unified. These two give the brand packaging inherent cultivation, and the external packaging complement each other. The brand concept of "Good Carpenter" conveys a style positioning that combines tradition and modernity. The "Tang Zong Chopsticks" is a simple and unique unified visual meta cable used throughout the body - the iconic slanted dividing line, and the standard colors of gold and black. Gold is the special color of the royal nobility, highlighting the noble characteristics, black is solemn, the combination of the two, simple and clear highlights the concept of elegance. The bold and innovative use of special paper makes the packaging of Tangzong chopsticks unique. "Hemu Tianxiang" in the brand concept into the positive qi Ding Run, benevolence, wisdom, courage, and other traditional Chinese culture essence, a large area of pure natural green reflects the essential characteristics of bamboo chopsticks, the pattern added bamboo, it contains the traditional culture of high quality for bamboo chopsticks.

Sum up: Traditional writing. The traditional Chinese characters such as seal cutting, brush characters and seals are accompanied by a deep breath of life under the accumulation of a long time, and through induction and concentration, the elements with common characteristics are extracted, so as to convey a cultural quality in the packaging design of bamboo chopsticks. For example, Chinese painting, which enjoys the reputation of elegance and tranquility, can enhance the sense of form in the text

modeling, and can convey to consumers the elegant and noble sensory experience like bamboo. While decorative, it embodies the unique visual effect and cultural heritage. Traditional colors. The traditional color is mostly used in bright red and yellow. Red festive, yellow noble, traditional color often contains the happy and auspicious beauty, is people's wish and blessing.

Xia Hongrui (2013) Write Article about Nature and design

Nature is a whole concept, but within nature there are many different regions and environments. In the earliest stages of human civilization, this gap was not obvious. Human beings are designed only to satisfy their most basic conditions of existence. However, with the continuous development of human society, human needs are increasing day by day, and people have a new understanding of nature. People in different natural environments have different understandings of nature, and different natural environments provide different substances, so people in different regions begin to carry out different designs. Here we take building houses as an example. The houses of residents in tropical rain forest areas are surrounded by a tree trunk, in a round or oval shape, covered with coconut leaves on the top, and there are no walls around the houses. This style is not only ventilated on all sides, but also conducive to cooling. Most wonderful of all are the Eskimos who live in the polar regions. They make full use of the materials provided by nature, the use of snow bricks built into the dome of the snow house, after the house is built, a fire in the room, the snow brick melts the gap between the bricks and bricks, and then dug a channel under the snow into the house, so that the snow channel makes it difficult to enter the room, and the warm air can gather in the house, played a role in resisting the cold. From here we can see that the same design house, but there are different styles and functions. This is precisely because the nature itself determines the diversity of human design, so as to meet the essential purpose of human design. Nature is the teacher of design Design is a creative activity, is a kind of innovation. But design is not a fantasy, but a regular plan. Through the observation of nature, human beings are surprised to find that all kinds of creatures in nature are so well designed. Some of them are admirably complete; Some of the structure is exquisite, reasonable materials; Some are too beautiful to put down. It is these various strange characteristics of creatures in nature that are intriguing, which makes human beings get countless inspirations from them. Lu Ban, the first artisan of our country, cut his leg on the way up the mountain by grass with toothed leaf edges. He was inspired by the appearance of grass and invented saw.

Sum up: With the development of human society, the special instinct shown by natural creatures also causes human thinking. For example, it was found that bats fly at night but can always avoid obstacles, and through exploration, humans discovered hypersonics and designed radar. And some of them are triggered by some kind of coincidence. An apple falling from an apple tree led Newton to discover gravity. The steaming kettle led Watt to invent the steam engine; Inadvertently smelting ores containing impurities, so that humans know how to make alloys. Nature and man are in this way each in their own way to push and pull each other, one to create a variety of coincidences, inspired by human "ingenuity", like a good teacher, a brave exploration, studious, like a student eager for knowledge. (Xia Hongrui 2013)

### Package design

Plane, three-dimensional structure and color picture as the basic support of commodity packaging design, through its flexible and innovative combination and application to make the commodity packaging more rich connotation and attractive. In the packaging design graphics, text and color into the ceramic elements, so that the design has the characteristics of primary and secondary, virtual and real combination, clear rhythm, can effectively attract the attention of consumers. As a symbol with Chinese historical and cultural characteristics, traditional ceramic elements also symbolize our national culture, so its intervention in packaging design has great possibilities and importance. In the current era of increasingly fierce cultural competition, the inheritance and development of national culture is the responsibility of each of us, the connotation of national culture into the packaging design, the design of products with the charm of eastern civilization, can improve the core competitiveness of dealers, and more importantly, can promote the enhancement of China's cultural soft power. The graphics and calligraphy art in traditional ceramic elements, as well as the integration of traditional national color emotion and modern elements show the unique historical and cultural value of the thought, which brings a strong visual impact and artistic appeal to consumers.

In the design of traditional ceramic elements, packaging designers need to have a solid foundation of professional design knowledge, but also have a keen awareness of the needs of consumer groups in modern society, and combine traditional cultural elements to improve the level of packaging design of goods on the basis of grasping the mainstream culture of society and changes in consumer demand. Only in order to carry out innovative design of packaging and reasonable use of traditional ceramic elements to increase the added value of goods, at the same time, it has a very positive role in the development and inheritance of China's traditional culture. The use of traditional ceramic elements combined with modern design forms to enhance the cultural value of commodities and meet people's spiritual and cultural enjoyment needs is an innovative commodity marketing means.

Sum up: Changes in commodity packaging design can be made by changing packaging materials, graphic color design and design concepts, through tangible or intangible changes to change product packaging, so that it has more aesthetic value and cultural value, so as to bring different experiences to consumers and meet their aesthetic needs. Therefore, the flexible application of traditional ceramic elements to tangible or intangible commodity packaging design can achieve three goals that simultaneously meet the cultural needs of consumers, the transmission of Chinese traditional culture and the innovative needs of dealers' marketing means, which has great value. Introducing Chinese traditional elements into the packaging design of modern ceramics can greatly enrich the historical sense of ceramic products, and can also spread the packaging design trend of the ceramic industry in the new era. The integration of Chinese traditional ceramic elements into modern commodity packaging design can greatly improve the sense of history of the product, but also lead the trend of modern commodity packaging design. For example, in the choice of commodity packaging materials, through the use of pottery material as the outer packaging of goods, not only to show another packaging style, so that consumers intuitively feel the charm of ceramic culture and Chinese traditional culture, its

ceramic elements make the commodity more historic and national, as well as unique cultural value.

Wang Gege (2015) Write book about Research on the application of bamboo elements in the design of modern Chinese dining space

In the splendid culture of the Chinese nation, bamboo has rich connotation and meaning, and people love to chant, praise, draw and use bamboo. Because bamboo is a simple but not delicate, straight and not weak symbol, but also a kind of indomitable character, is the representative of the Chinese national spirit and national integrity.

In the interior design, bamboo exists in three colors: green, grayish yellow and carbonized. First of all, when the green bamboo meets our eyes, it can produce a fresh and vibrant feeling. Yellow, on the other hand, can give people a warm, fruitful and pleasant psychological reflection, while carbonized bamboo can give people a stable and solemn visual feeling. In short, different colors of bamboo give people different feelings and make people positive.

In the design performance, we should make full use of the material texture and structure of bamboo itself, and use its shape as a decorative pattern in interior design. From the appearance point of view, the bamboo grain arrangement is tight and neat, and has a certain toughness and hardness. From the perspective of processing technology, the processing process of bamboo is simple and varied.

Sum up:As a representative material of "structure" in interior design, bamboo is mainly reflected in the structural connection between space and space. This not only reflects the interrelation between the various spatial elements, but also realizes the unity of the whole space.

Bamboo expresses a kind of human spirit endowed with moral meaning by means of intention and sensibility. First, the bamboo interface can be used for decoration. Bamboo exists in a variety of styles, such as bamboo poles and bamboo boards, and is widely used in the decoration of indoor walls, tops, floors and doors and Windows, reflecting the diversity of its decoration. Secondly, in modern life, the use rate of bamboo furniture is also getting higher and higher, and its green environmental protection has been favored by the public. In the Ming and Qing dynasties, furniture has the combination of bamboo and wood, among which, the most representative number of Qing Dynasty Guang-style bamboo pattern furniture. Third, bamboo generally exists in the form of walls, suspended ceilings, antique shelves, display shelves, etc., with exquisite craftsmanship and unique appearance; In the decoration design, choose to use bamboo decorations, that is, to achieve the decorative effect of "moving nature on the case". Finally, using bamboo to imitate the scene, bamboo is used in the space layout as a decorative space, such as the small bridge water landscape and bamboo pole partition landscape, reflecting people's tendency to pursue nature.

Gu Xiaoping (2021) Write book about Packaging design under the modern concept

The packaging design of the gift is to upgrade the product. The main performance is, on the one hand, through the packaging design reasonable integration of relevant elements. One is the structure of paper packaging. Mainly with pulp or waste paper as raw materials, the finished product is cardboard and wrapping paper two types.

Wrapping paper material is relatively thin and soft, can not be fixed shape, generally as a commodity bag, packaging material and insulation material; The material of cardboard is relatively rigid, and it is generally displayed in various forms such as gift boxes, gift cans, and so on.

Sum up:Compared with other forms of packaging materials, paper packaging structure has the characteristics of easy folding, convenient recycling, easy opening and so on. With the rapid development of the packaging industry, paper packaging technology is widely used in gift packaging based on modern concepts of fruit gift packaging design, mainly from the shape design, size design and structure.

Shi Xiaoxia (2021) Write book about The application of bamboo in packaging design

Bamboo has beautiful shape and is one of the most aesthetic plants in nature. Bamboo shoots, rods, joints, branches and leaves show different morphological structures due to different growth laws. The application of these morphological and structural elements in packaging can enable consumers to obtain a distinctive aesthetic feeling close to nature. In the specific design process, on the basis of analyzing the various local forms of bamboo, the natural forms of bamboo should be transformed and extracted according to the needs of the design, and expressed with modern design techniques.

Yunnan bamboo tube wine is a successful example of the use of bamboo form, and the whole design fully reflects the wisdom of the minority nationalities in using bamboo. The bamboo tube used in the wine is selected from the high-quality sweet bamboo in the mountains of Yao Township, and its shape is straight and beautiful. Bamboo tube directly into the wine, bamboo fragrance slowly dissolved into the wine, it can be said that the bamboo tube from the internal quality and external beauty of the two aspects to enhance the quality of wine. As one of the most distinctive products in Yunnan, bamboo tube wine has won a number of national awards, among which the bamboo tube as a packaging has played a very important role.

Bamboo is a kind of natural renewable material with short growth cycle, abundant resources and superior performance. In line with the green trend of modern packaging design. In the packaging design, we should use the aesthetic vision to look at the quality of bamboo, find the entry point of the application of bamboo quality, and skillfully integrate the aesthetic feeling of material and packaging design. In view of the special properties of bamboo, packaging design should not only understand the general properties of the material, but also deeply analyze and grasp the processing and creation of bamboo. The development of The Times and the progress of science and technology have expanded the function and value of bamboo materials, making it show a more scientific and superior attribute in packaging. John Varvatos (John Varvatos) is an American fashion clothing brand, known for its simple texture and

sophisticated collocation. It launched a Master Craftsman Artist bamboo woven men's perfume, a refined transformation of the traditional woven form, paired with glass materials. It is precisely because of the application of bamboo weaving, the characteristics of the perfume packaging design are "highlighted by the material", which not only maintains the natural and fresh characteristics of the original bamboo, but also creates a modern simple and exquisite style through the creation and processing.

Sum up: In the long life practice and historical activities, people personify the material characteristics of bamboo and raise it to the moral character of the spiritual level. Seeing bamboo will make people think of modesty, elegance, integrity, straightforwardness and other beautiful characters, these spiritual characteristics carried by bamboo are the core connotation of bamboo culture, but also the inexhaustible spiritual wealth. In the field of packaging design, at the cultural level, we try to explain the cultural connotation and aesthetic value of bamboo with modern design language, and transform it into a unique visual symbol. "Bamboo" is the best entry point for packaging design. In the bottle design of the national treasure bamboo leaf green wine, the bamboo leaf shape is adopted, and the single bamboo leaf is vertically rotated 360 degrees as the basic shape of the bottle body, which visually conveys the fine quality of the wine inheriting the ancient formula of bamboo leaves. In the selection of packaging materials, in order to better highlight the brand characteristics, the selection of natural lightweight bamboo as the side panel of the outer packaging box. In the decoration design of the packaging box, the color is directly selected the green tone of natural bamboo, fresh and natural. In the graphic design, Golden Elephant Bamboo Leaf Green wine uses bamboo as the theme of traditional Chinese painting decoration, which indirectly transfers bamboo as the cultural symbol of the four gentlemen to the wine, making it stand out in the liquor market.

#### Return to the nature of bamboo packaging design

Bamboo processing has also been rapid development, no longer like the traditional use of bamboo, bamboo has been widely used in the manufacture of a variety of high-grade bamboo plywood, fiberboard, bamboo scrap board, bamboo composite board, crafts, etc., beautiful and durable, its performance indicators far more than the general wood. In the use of ecological value, because bamboo is evergreen, it is widely used in soil and water conservation, windproof soil consolidation, climate regulation, beautify the environment.

Sum up: Bamboo has a variety of forms, rich rod shape, elegant and subtle charm, with the improvement of people's aesthetic awareness, a variety of garden bamboo species are increasingly favored by people, and are widely used in landscape architecture industry, and bamboo gardens have been established in various places. It is no wonder that the ancient poets have the aphorism "not one day without this king" and "It is better to eat without meat than to live without bamboo."

## 1.8. Conceptual Background

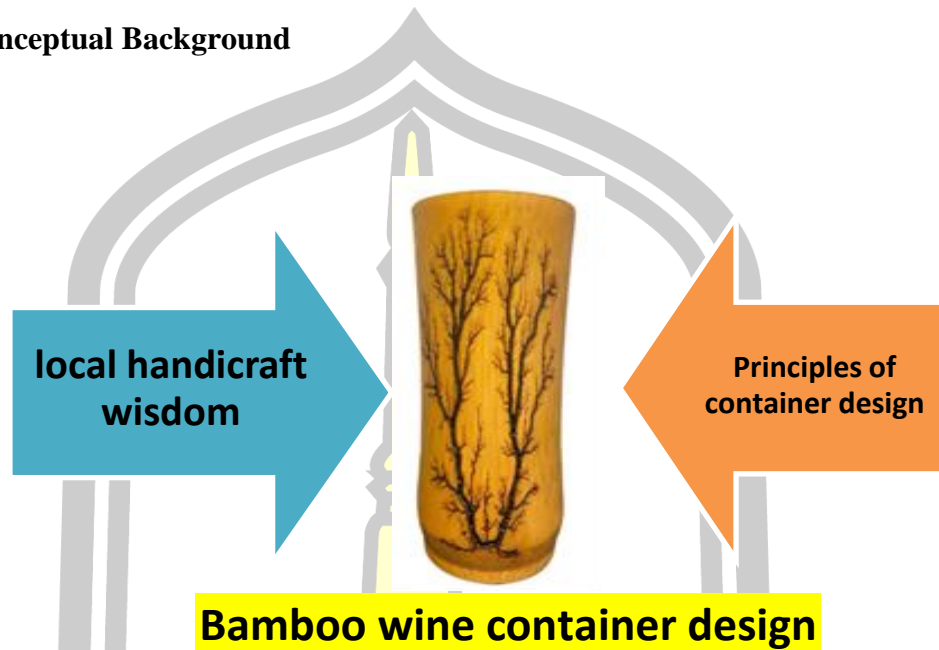

Figure 1

### 1.8.1. Local handicraft wisdom

The craftsmanship wisdom of bamboo wine set is mainly reflected in its design, material selection, production skills and cultural connotation.

From the design point of view, fully show the creativity and ingenuity of the craftsman. Whether it is a glass or other wine utensils, its shape is integrated into the beauty of nature, as if every piece of work is the crystallization of harmonious symbiosis between nature and man. This design is not only beautiful and generous, but also complement the unique flavor of Maoershan bamboo wine, so that people can feel the strong artistic atmosphere while tasting the wine.

In terms of material selection, it also reflects the wisdom of the artisans. We know that bamboo, as a natural material, has a unique texture and texture, but also has the advantages of environmental protection and renewable. Therefore, when making wine sets, craftsmen select high-quality Maoershan bamboo and carefully treat it, so that it not only retains the natural beauty of bamboo, but also has good practical properties.

In terms of production skills, it embodies the painstaking effort and wisdom of the artisans. From the cutting and handling of bamboo to the shaping and polishing of wine utensils, every step requires fine skills and rich experience. Craftsmen use traditional manual skills and modern tools to carve bamboo into a variety of exquisite shapes, making it both practical and ornamental.

As a special handicrafts, it is not only a tool for wine tasting, but also a carrier of culture. Through Maoershan bamboo wine set, people can feel the unique local

customs and cultural atmosphere, so as to deepen the understanding and knowledge of this land.

The wisdom of handicraft is reflected in its unique design, precision of material selection, exquisite production skills and profound cultural connotation. These wisdom not only makes the bamboo wine set a practical and beautiful coexistence of good products, but also the inheritance and development of local handicraft culture.

### 1.8.2.Principles of container design

Container, as a standardized and modular logistics vehicle, plays an important role in the modern logistics industry. It is widely used in the fields of cargo transportation, warehousing management and multimodal transportation, which greatly improves logistics efficiency and cost effectiveness.

When designing containers, follow the following basic principles to ensure superior performance, safety and reliability:

**Structural strength:** Containers need to withstand various external forces during transportation, such as vibration and impact. Therefore, the design should ensure that the container has sufficient structural strength to prevent deformation, damage and other problems.

**Durability:** Containers should have a long service life to cope with long-term, frequent transportation needs. The design should consider the use of wear-resistant, corrosion-resistant and other excellent materials to improve the durability of the container.

**Safety:** The container should ensure the safety of goods and personnel during transportation. In the design, the stacking stability of the goods and the sealing of the box should be fully considered.

#### Key components and material selection

The design of containers involves key components and materials, including:

**Box:** The box is the main carrying part of the container, usually made of high-strength steel. The size, shape and load-bearing capacity of the box should be considered in the design to meet the transportation needs of different goods.

**Door:** door should have good sealing performance and easy to open, the common design has sliding door and swinging door.

### 1.8.3.Bamboo wine container design (Combined with the above two design)

Considering the structural strength and stability of container design principles. In the design of bamboo containers, we can make use of the natural toughness and strength of bamboo, and ensure the robustness and durability of the containers through reasonable structural design.

The wisdom of bamboo and wine handicraft provides inspiration. The design of bamboo wine sets often integrates the beauty of nature and the charm of humanity, and integrates this aesthetic concept into the design of bamboo containers. In terms of shape, drawing on the curve and outline of bamboo wine utensils, the container presents an elegant and natural aesthetic feeling. At the same time, the natural texture and color of bamboo are used to make the surface of the container more smooth and delicate through grinding and polishing, adding a sense of texture and taste.

The combination design of container design principle is worth learning. Bamboo containers can be modular design to achieve different size combinations.

In terms of environmental considerations, you can choose to use environmentally friendly bamboo as a raw material and avoid the use of toxic or harmful chemicals.

Bamboo wine craft and container design principles designed bamboo containers, will integrate the beauty of nature, humanistic charm and practicality, both beautiful and durable.

### **1.9.Benefits of Research**

#### 1.9.1.For craftspeople or designers :

The research provides a new creative idea and inspiration . Through studying the traditional handicraft skills of bamboo wine set and combining the modern design concept of container design principle, the bamboo container design with traditional charm and modern aesthetic needs can be innovated. Help to enhance professional skills and creative level, promote the integration of crafts and design development.

#### 1.9.2.For environmental advocates:

The study offers an environmentally friendly and sustainable alternative. The use of bamboo containers can reduce the dependence on traditional non-renewable materials such as plastics and metals, and reduce energy consumption and environmental pollution in the production process. This kind of research helps to promote the application of environmental protection concepts in real products and promote sustainable development.

#### 1.9.3,For ordinary consumers:

The bamboo containers brought by the research not only have beautiful appearance and practical functions, but also carry rich cultural connotations. The use of such containers can enhance the quality of life and cultural experience, and meet the pursuit of ordinary consumers for personalized, environmentally friendly and sustainable living.

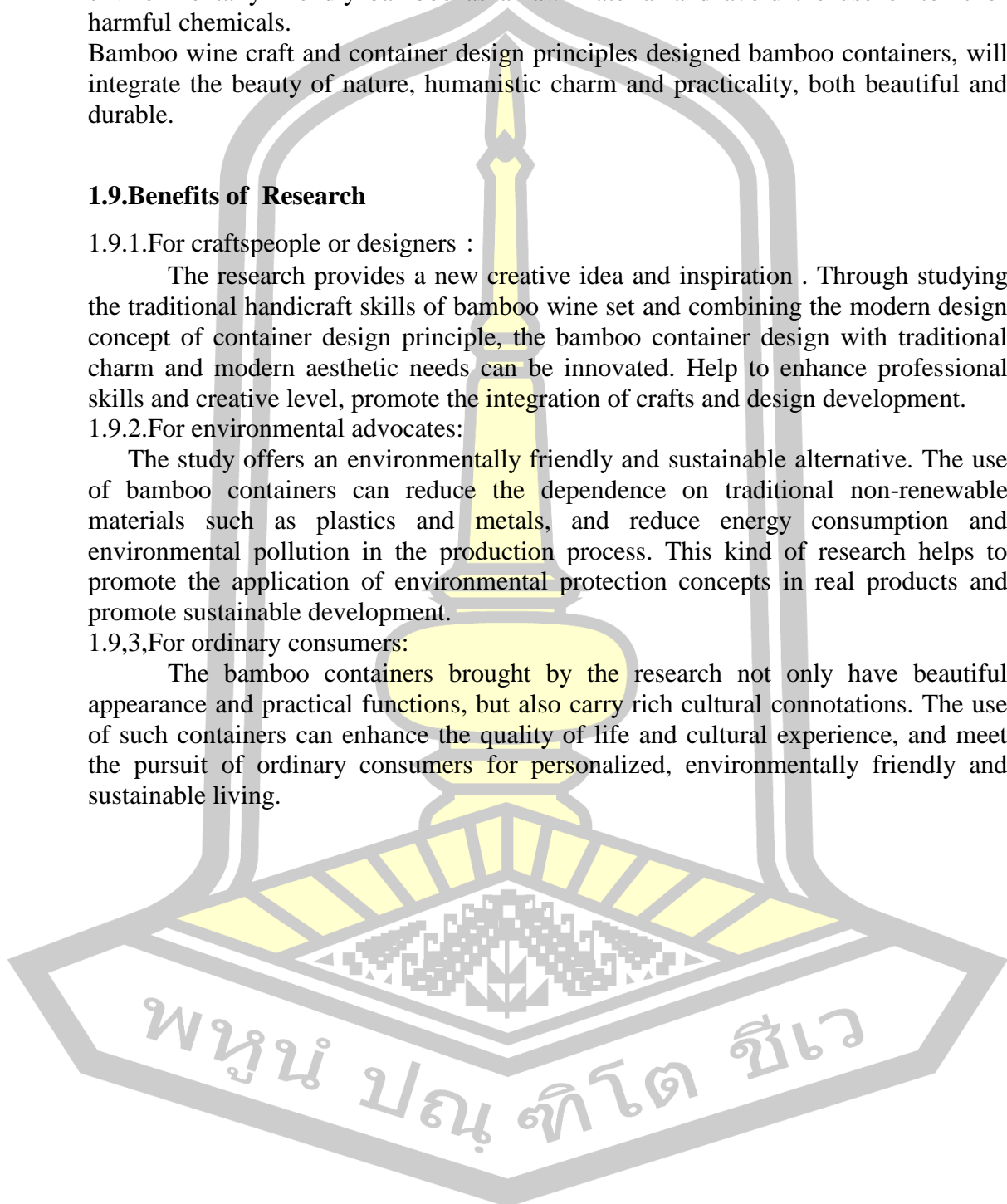

## CHAPTER II

### The current situation of bamboo wine packaging

In the design, it not only pays attention to people's traditional aesthetic psychology and the pursuit of novel appreciation habits, but also achieves the perfect combination of bamboo packaging form and product content, adding new ideas to the modern and colorful packaging design field. (Kong Fei 2010)

As a category of modern packaging design, wine packaging design should follow the basic principles of science, practicality, economy, aesthetics, creativity and so on. Modern wine packaging design breaks through the concept of traditional wine packaging, is the perfect combination of technology and art, is a means to beautify life and create commercial value. (Meng Ruihua 2006)

#### 2.1. Development of Chinese bamboo handicrafts

##### 2.1.1 Bamboo wine packaging begins :

Bamboo packaging is one of the earliest packaging products manufactured and used by human beings. Direct use of bamboo leaves and bamboo shells to wrap items can be traced back to about 10,000 years ago. After slight processing, bamboo tubes and mat wrapping items have a history of about six or seven thousand years. Bamboo packaging containers were used as early as around 4000 BC. More than 200 pieces of bamboo woven containers, such as baskets, baskets, and dust pans, were unearthed from the Late Neolithic site of Qianshanyang, Zhejiang Province (about 3000 BC), which are the earliest bamboo packaging objects in the world. These bamboo woven objects, the bamboo strips are smooth and uniform, and the weaving is quite exquisite. Refined bamboo products appeared about 800 years before 1000 BC.

As a kind of wine set, the history of bamboo wine set can be traced back to ancient times. As early as the Neolithic culture period, there has been a similar shape to the later wine ware pottery, which can be regarded as the early form of wine ware.

Bamboo wine set especially in the southern region has been developed, which is closely related to the cultural customs of ethnic minorities in the south. Drinking in bamboo cups has formed a unique custom.

"Liji · Yuzao" records that in the Western Zhou Dynasty, the literati held the board, which was made of bamboo and engraved with ornaments. In the practice process of production and life, various ethnic groups in the south make full use of the natural bamboo itself to make utensils for production and life, especially the bamboo space to contain water liquids. These bamboo utensils are all real utensils. In order to express the attribution of bamboo utensils, simple symbols are carved on bamboo utensils among various clans and families.

As early as the Spring and Autumn Period and the Warring States Period, bamboo ware has become an important daily necessities. The main process of bamboo production includes material selection, splitting, weaving, grinding and painting. In

the production process, the craftsmen make full use of the characteristics of bamboo to make a variety of practical and beautiful bamboo ware. Nowadays, bamboo making has become a unique arts and crafts, providing people with convenient and elegant daily necessities.

At the end of the Eastern Han Dynasty, there were frequent wars all over the country, and they moved to the south to escape the war. In Ninghua wilderness area, there is a long way to open up the land, there is no wine container, and the open land is not comfortable to travel long distance, feeling upset and impatient, and the original residents are rumored to be able to settle the panic and remove the annoyance and annoyance. The local bamboo resources have always been rich, and the zunter suddenly thought: why not combine the wine that raises the spirit with the bamboo that calms the heart into another fine wine? In order to replace the original ceramic wine container, work with bamboo wine tasting, long-term drink refreshed, a hundred times the spirit, fragrance heart, slightly bitter and clear alcohol sweet, meaning such as hidden transfer through the war, reclamation and other twists and turns and then get a harmonious and peaceful life, so the generations.

Bamboo carving art originated in the Tang Dynasty and is one of the traditional Chinese crafts. There are many schools of bamboo carving, mainly Jiading school, Jinling school, Zhejiang school and so on. Each school has a unique style, such as the Jiading school with shallow carving, Jinling school with deep carving and deep carving. Representative works such as Jiading school's "Qiushan Travel Map" and Jinling School's "Ming Xuande Bamboo Carving Lady" all show the exquisite skills and unique charm of bamboo carving art.

Guangxi, located in the south of China, has been a region rich in natural resources and with a long human history since ancient times. In this land full of vigor and vitality, people have created many handicrafts with unique charm and cultural connotation with diligence and wisdom. Among them, Guangxi traditional bamboo packaging handicrafts, with its unique material, exquisite craft and profound cultural connotation, has won widespread praise and love.

Guangxi is densely covered with bamboo forests, which provides unique natural conditions for the production of bamboo handicrafts. Bamboo is light in texture, beautiful in texture, easy to process, and has good environmental protection properties, so it becomes the ideal material for making packaging handicrafts.

Traditional bamboo packaging handicrafts are famous for their simple and generous shape, elegant natural texture and fine craftsmanship. The bamboo vases and ornaments used for decoration reflect the people's love for life and pursuit of beauty.

The production skills of traditional bamboo packaging handicrafts have a long history and have been inherited for hundreds of years. In the production process, artists need to go through the selection of materials, peeling, cutting, weaving, grinding and other processes, each process requires exquisite skills and rigorous attitude.

In the process, different methods and techniques will be adopted according to different needs and uses. Traditional bamboo packaging handicrafts not only have practical functions, but also carry rich cultural connotation and national spirit. These handicrafts are the crystallization of the wisdom of the Guangxi people, reflecting their reverence for nature and love for life.

Bamboo packaging handicrafts also have important economic value. With the improvement of people's living standards and the increasing attention to cultural consumption, these handicrafts are gradually favored by the market. They not only have a share of the domestic market.

With the acceleration of modernization and the impact of industrial production, the survival and development of traditional bamboo packaging handicrafts are facing severe challenges.

It is particularly important to strengthen the protection and inheritance of traditional bamboo packaging handicrafts. Guangxi traditional bamboo packaging handicraft is an important part of Guangxi unique culture, with high cultural value and artistic value. We should work together to protect and pass on this precious cultural heritage, so that it will glow with more brilliant splendor in the new era.

#### 2.1.2 Bamboo wine packaging in the past :

In ancient Chinese wine culture, wine vessel is not only a container of wine, but also a carrier of culture, which has formed a close interactive relationship with wine culture. This relationship is reflected in the design, production, use and symbolic meaning of wine vessels. The design and manufacture of wine vessels are deeply influenced by wine culture. In different historical periods, the shape, material and craft of wine vessels all reflect the characteristics of wine culture at that time. For example, the bronze wine vessels of the Shang and Zhou dynasties, with solemn shape and complex decoration, reflected the nobles' attention to wine and cumbersome etiquette. In the Tang and Song dynasties, porcelain wine ware became popular, and its delicate craft and unique shape reflected the aesthetic pursuit of wine and the change of life style of the society at that time. The use of wine vessels is also an important part of wine culture. In ancient China, the use of wine vessels had strict etiquette norms. Different identities, different occasions, the use of wine vessels are different. The use of wine vessels, such as wine, toast, drinking, etc., also contains profound cultural connotations. The use of these etiquette norms not only reflects the etiquette system of ancient China, but also shapes people's understanding and cognition of wine culture. Wine vessels also have rich symbolic significance, which further enriches the connotation of wine culture. Wine vessels are often used as a symbol of power, such as the allusion of "a cup of wine to release military power", which reflects the important role of wine vessels in the political power struggle. Wine vessels also symbolized wealth and status, such as precious wine vessels were often used as gifts between nobles to highlight their wealth and status. There is a close interaction between wine ware and wine culture. The design and production of wine vessels are influenced by wine culture, the use of wine vessels reflects the etiquette norms of wine culture, and the symbolic meaning of wine vessels enriches the connotation of wine culture. This interactive relationship makes the wine ware play an important role in the ancient Chinese wine culture, but also makes the wine culture more colorful.

In the Shang Dynasty, due to the gradual development and maturity of wine-making technology, it has been able to produce different varieties of wine with various grains, coupled with the relatively developed bronze culture, the prevalence of sacrifice, bronze wine glasses came into being. Moreover, the quantity of production,

the variety of the whole, the beauty of the decoration, and the precision of the production are unprecedented, which has become an important part of the "ritual vessels" held by the slave owner class, and has also become a symbol of status.

The types of wine glasses have also developed to serve wine, warm wine, drinking, storing wine and other categories.

By the Spring and Autumn Period, the Chu state in the middle and lower reaches of the Yangtze River had been able to produce bamboo in batches, of which packaging accounted for more than half. West Han Dynasty popular with bamboo dress food all kinds of daily necessities, bamboo box dress also became popular.

A large number of bamboo objects containing objects was unearthed from Mawangdui Han Tomb in Changsha. During the Tang and Song dynasties, bamboo weaving combining practical and craft came out, such as various kinds of supporting baskets, gift boxes, special-shaped bamboo baskets, etc., with high artistic value.

The open, free and easy social atmosphere makes the wind of drinking poetry popular, and the Tang people have reached a new height in the production process and modeling requirements of drinking utensils. This era is full of novel ceramic wine sets, exquisite gold and silver wine sets, precious jade wine sets.

In Yuan, Ming and Qing dynasties, bamboo carving products gradually changed from practical to artistic. Flowers and birds, calligraphy, landscape are often selected as the theme of bamboo carving artists, a large number of stationery such as pen holder, incense, paperweight, arm rest, brush wash, etc., are carved from bamboo, and there are also decorative objects for watching and playing, such as small pavilions, figures, wall hangings, good luck, wine utensils and so on. Bamboo wine containers can not only make the wine produce a unique style of elegant bamboo fragrance, soft and sweet, but also reflect the broad and profound Chinese wine culture.

Ming Dynasty is an important stage of ancient Chinese culture, and the production of wine utensils has also made great progress. The wine set of Ming Dynasty is widely sought after for its simple and generous design style. In the Ming Dynasty, the craft of making wine sets reached its peak, and the unique wine sets began to appear, which laid the foundation for the development of later wine sets. The Qing Dynasty was the peak period of ancient Chinese wine set making, the making technology of wine set was more fine, and the decoration was more exquisite.

By the Ming and Qing Dynasties, bamboo woven products were popular and commonly used by the people.

Zhao Ruzhen, an antique collector in the late Qing Dynasty, summed it up in his "Antique Guide · Bamboo Carving": "Bamboo carving, bamboo carving. His works are the same as calligraphy and painting, but with a knife and bamboo as paper ears. The difficulty of painting and calligraphy is well known. Today, it is easy to use a knife and bamboo, but it is more difficult than painting and calligraphy." He compared bamboo carving with calligraphy and painting, using a knife instead of a pen to create on bamboo, which is difficult to imagine.

Bamboo carving art refers to the use of carving technology to create a variety of images on bamboo art form. The history of bamboo carving art can be traced back to the Tang Dynasty, to the Ming and Qing dynasties, bamboo carving art has been very mature, and formed a number of schools, such as Jiading school, Jinling school. The works of each school have unique styles, such as the "staying green" technique of

the Jiading school and the "deep carving" and "penetrating carving" techniques of the Jinling School, which all reflect the exquisite skills and rich expression of bamboo carving art. Representative works such as "bamboo carving literati elegant collection" of Jiading School and "Bamboo carving Ladies" of Jinling School are treasures of bamboo carving art.

### 2.1.3 Now bamboo wine packaging :

With the development of The Times, the traditional wine set production is gradually combined with modern technology, and many new wine sets have appeared. For example, glass wine has become a highlight in the production of modern wine, its transparency and texture give people a new drinking experience. In addition, stainless steel, plastic, ceramics and other materials are also widely used in the production of modern wine.

With the rise of the packaging industry, saving packaging materials and preventing packaging waste from polluting the environment have become a matter of great concern to countries around the world, and packaging materials have a very close relationship with the environment. In the increasingly colorful packaging design today, packaging design workers have been constantly exploring new green packaging materials, all return to nature.

The application of modern design concepts. Using modern design concepts, including simplicity, fluency, function, etc., bamboo wine set design. Pay attention to the practicability and man-machine interaction of the wine set, improve the comfort and convenience of the use of the wine set. At the same time, combining the characteristics of bamboo and traditional crafts, it shows a unique modern sense and cultural charm.

The embodiment of cultural value. The traditional Chinese cultural elements and bamboo cultural characteristics are integrated into the design, reflecting the cultural value of bamboo wine sets. Through the design language and decoration techniques, the elegance, tenacity and natural beauty of bamboo are shown, as well as the connotation and charm of traditional culture. At the same time, combined with modern concepts and environmental awareness, give bamboo wine set more cultural significance and social value.

As an important part of Chinese traditional culture, wine and wine vessels not only reflect the ancient people's love and pursuit of life, but also contain profound cultural connotation and philosophical thoughts. Wine, as a special drink, has played an important role in the long history of China since ancient times. Whether it is ancestor worship, harvest celebration, friends gathering, poetry, wine is an indispensable element. The wine vessel, as the carrier of wine, its shape, material and craft all reflect the aesthetic concept and technical level of the society at that time. Wine and wine vessels are closely related to traditional culture. They not only carry the life memory and emotional sustenance of ancient people, but also embody the etiquette, morality and aesthetic concepts of traditional Chinese culture. In ancient times, the use of wine vessels had strict norms and attention, such as the order of the upper and lower, the order of the elder and the younger, etc., which reflected the etiquette system in Chinese traditional culture. At the same time, wine has also been given moral implications, such as "wine friends a thousand cups less, more than half a

sentence", which reflects the traditional Chinese culture attaches importance to interpersonal relations and the characteristics of the world. In modern society, wine and wine utensils are still important. On the one hand, with the improvement of people's living standards and the change of aesthetic concepts, the design and production of wine utensils also pay more attention to individuation and art, and become a symbol of people's pursuit of quality of life and cultural taste. On the other hand, as a social medium, wine plays an important role in business activities and social occasions, helping to promote communication and cooperation between people. Wine and wine vessels also carry the function of cultural inheritance and historical memory. Through the study of ancient wine vessels and wine culture, we can better understand the customs and aesthetic concepts of ancient society, and also provide inspiration and reference for the cultural innovation and artistic design of modern society. Wine and wine utensils have a close and profound relationship with traditional culture. They are not only an important part of traditional Chinese culture, but also play an important role in modern society. We should cherish and inherit this precious cultural heritage, so that it can glow with new glory in modern society.

Bamboo, as an important element of Chinese traditional culture, not only occupies a place in the natural landscape, but also plays an indispensable role in the handicraft of wine utensils. Since ancient times, bamboo, with its unique material characteristics, exquisite production technology and profound cultural connotation, has become a gem in the production of wine utensils. This article will discuss the importance of bamboo in wine craft, as well as its value and development in modern society.

Bamboo has a long history in Chinese wine craft. As early as ancient times, people began to use bamboo to make wine utensils, such as bamboo cylinder wine, bamboo cups and so on. These bamboo wine sets with its simple and simple shape, light and strong texture, became an important part of people's drinking culture at that time. With the changes of The Times, the application of bamboo in the handicraft of wine is gradually rich, and the production skills are increasingly exquisite.

Bamboo is widely welcomed because of its unique material characteristics and environmental protection concept. The pursuit of environmental protection, health and nature makes bamboo wine sets have great potential in the market.

Bamboo has many advantages as a raw material for wine. First of all, bamboo is light in weight and good in toughness, making the wine set both light and durable. Secondly, bamboo has good breathability and heat preservation, which can maintain the temperature and taste of the wine. In addition, as a renewable resource, bamboo has environmental protection and sustainable characteristics, in line with the green development concept of modern society.

From bamboo to the production of exquisite wine utensils, it needs to go through many processes and skills. First of all, to choose high-quality bamboo as raw materials, after drying, to knot, cutting and other primary processing. Then, according to the design pattern for engraving, grinding and other fine processing, so that it presents a unique shape and texture. Enhance the ornamental value of the wine set.

In the production process, the skill and experience of the craftsman are crucial. They need to master a variety of tools and skills to skillfully transform bamboo into exquisite wine utensils. It is this exquisite skill and unremitting pursuit that makes bamboo wine set with unique charm and value.

The cultural connotation and aesthetic value carried by bamboo wine set is one of the important reasons why it is highly respected in modern society. Bamboo is a symbol of resilience, modesty and elegance in Chinese culture. The use of bamboo wine sets can not only taste the fine wine, but also feel the profound cultural heritage and historical inheritance.

Bamboo wine set also has a unique emotional meaning. In modern society, people's love for traditional culture and handicrafts is heating up. The use of bamboo wine sets can not only meet people's pursuit of beauty, but also convey people's yearning and expectation for a better life.

It is environmentally friendly and contributes to sustainable development. As a kind of renewable resources, bamboo has the characteristics of rapid growth and easy planting. Using bamboo to make wine utensils can reduce the consumption and waste of limited resources and reduce the pollution and damage to the environment.

Innovative design on the basis of protecting traditional cultural resources is an inevitable trend for the future development of bamboo wine set crafts. Through the introduction of modern design concepts and technical means, combining traditional elements with modern aesthetics, bamboo wine sets with the atmosphere of The Times and unique charm are created.

An important way to promote the innovation and development of bamboo wine set crafts. Through the integration and interaction of related industries, we can expand the application fields and market space of bamboo wine sets, and improve the competitiveness and influence of f in modern society.

Bamboo plays an important role in the handicraft of wine set. Its unique material characteristics, exquisite production technology and profound cultural connotation make bamboo wine set a treasure in traditional culture. In modern society, bamboo wine set not only has environmental protection significance and market potential, but also can carry people's yearning and expectation for a better life.

The understanding and inheritance of bamboo wine set handicraft, through technological innovation and cross-border cooperation to promote its continuous development and growth. At the same time, attention should also be paid to cultivating the young generation's awareness and love for traditional culture and handicrafts, so that this valuable cultural heritage can be passed on and carried forward

Bamboo plays a vital role in the packaging of bamboo wine. The natural material and texture of bamboo give the packaging a unique texture and beauty, making the product more eye-catching. As a renewable resource, bamboo has the characteristics of environmental protection and low carbon, bamboo wine packaging has become a green and healthy packaging choice.

Bamboo wine packaging integrates traditional handicrafts and modern design concepts, showing unique cultural charm and creativity. Through the clever use of bamboo and innovative design, designers make bamboo wine packaging not only practical, but also become an important carrier to display product personality and cultural connotation.

Bamboo wine packaging also plays an important role in the protection of wine. Bamboo has good sealing and stability, which can effectively protect the quality and taste of wine and extend its shelf life.

The importance of bamboo in bamboo wine packaging is mainly reflected in its unique texture, beauty, environmental protection, cultural connotation and the function of protecting wine.

Designers can draw inspiration from ancient bamboo wine containers and inherit its classic elements. This includes the natural texture of bamboo, the shape of bamboo joints, as well as traditional weaving and carving techniques. Through the clever use of these elements, the newly designed bamboo wine container can be endowed with a unique cultural charm and historical sense.

While inheriting classic elements, designers also need to incorporate modern design concepts into the design of bamboo wine containers. This includes modern aesthetic concepts such as simplicity, practicality and environmental protection, as well as modern scientific and technological means such as ergonomics and material science. By integrating these modern elements, the newly designed bamboo wine container can be more in line with the aesthetic needs and usages of modern people. Innovative materials and processes

In addition to inheriting classic elements and integrating modern design concepts, designers can also create unique bamboo wine containers through innovative materials and processes. For example, you can try to use different kinds of bamboo or specially treated bamboo to make wine containers to show a unique texture and visual effect.

In terms of modern design, many designers began to try to apply the knowledge of ancient craftsmanship to the design of bamboo wine containers. By refining and recreating traditional elements, a bamboo wine container with both classical charm and modern beauty was designed. These new bamboo wine containers not only retain the essence of the traditional process, but also integrate the concept and elements of modern design, making the traditional bamboo wine containers radiate new vitality and vitality

At present, there are some shortcomings in the research of bamboo wine container design. On the one hand, the excavation and sorting of ancient craft knowledge is not deep and comprehensive enough; On the other hand, the innovation and practice of modern design still need more exploration and practice. Therefore, future research can be carried out in the following aspects:

First of all, strengthen the excavation and sorting of ancient craft knowledge. Through in-depth study of ancient literature and material materials, further excavate the connotation and value of ancient craft knowledge, and provide more reference and reference for modern design.

Secondly, explore the fusion of ancient craft knowledge and modern design. How to integrate the concept and elements of modern design on the basis of retaining the essence of traditional craft is an important problem in the design of bamboo wine containers. Future research can find a better way of integration through practical exploration and summing up experience.

Bamboo, as one of the "four gentlemen" in traditional Chinese culture, has won people's love for its unique toughness and elegant form. Bamboo wine container, using natural bamboo, carefully designed and made, not only retains the pristine and ecological beauty of bamboo, but also integrates modern design concepts, a new visual and tactile experience.

Each bamboo wine container is a small emotional container. When consumers taste the wine at the same time, they can also feel the fresh and quiet from nature. Bamboo wine containers can carry these emotions perfectly, so that consumers can feel the flow and resonance of emotions while tasting wine.

Bamboo wine container design can cleverly integrate the story, history and meaning of the company or product. Whether it is the centuries-old winemaking skills, or the awe and protection of nature, it can be demonstrated through the design of bamboo wine containers, thus triggering the resonance and recognition of consumers.

The making process of ancient Chinese wine vessels has a long history, but in modern society, wine culture continues to evolve, and wine vessels continue to integrate between tradition and innovation. The progress of modern craft technology has made the production of wine vessels more refined and diversified, but also injected modern aesthetic elements. Some designers have combined the traditional wine vessel shape with the contemporary art style to create a new wine vessel with a unique sense of The Times, which has injected new vitality into the inheritance and development of Chinese wine culture.

Bamboo is a fast growing, renewable plant with a short growth cycle and little negative impact on the environment. Therefore, the use of bamboo to make wine utensils can greatly reduce the dependence on non-renewable resources and reduce the damage to the environment.

Bamboo absorbs carbon dioxide as it grows, helping to slow global warming. The waste generated during its processing and use is also easy to degrade and friendly to the environment.

With unique aesthetic and cultural value, bamboo has a unique texture and color, and its unique appearance makes bamboo wine sets visually present a different aesthetic feeling.

In the process of making bamboo wine sets, traditional crafts and cultural elements are often integrated, such as bamboo weaving, bamboo carving, etc., so that it has high cultural value and can inherit and carry forward traditional culture.

Health and safety, bamboo natural non-toxic, does not contain harmful substances, the use of bamboo made of wine will not cause harm to human health.

Compared with some plastic or metal wine sets, bamboo wine sets will not chemically react with the ingredients in the wine when storing the wine, maintaining the original flavor of the wine.

Economical and practical, bamboo resources are rich, widely distributed, the price is relatively low, using bamboo to make wine sets can reduce production costs and improve economic benefits.

Bamboo wine set is light and durable, easy to carry and clean, in line with modern life style and aesthetic needs.

To promote cultural inheritance and innovation, bamboo wine set, as the carrier of traditional culture, contains rich cultural connotation and national characteristics in the process of production and use, which is helpful to inherit and carry forward national culture.

Integrating traditional elements into modern design can realize cultural inheritance and innovation, and promote the diversified and personalized development of bamboo and wine set design.

In line with modern consumption trends, consumers are increasingly concerned about environmental protection and health issues, and the demand for green and environmentally friendly products is also increasing. The use of bamboo to make wine utensils is exactly in line with this consumption trend, and can meet the needs of consumers for environmental protection and health.

Bamboo wine making not only has environmental protection, health, safety and other advantages, but also has a unique aesthetic.

## **2.2.Current situation of bamboo wine packaging**

As a combination of traditional culture and modern design concept, bamboo wine packaging has been widely concerned and favored.

In the design of the main simplicity, carved on the lid of bamboo, ink painting and different "wine" characters gathered into a river to represent the long history of wine culture.

In view of modern people's aesthetic needs and functional needs, bamboo wine vessels also need to carry out modern modeling and design. Through the exploration of modern art and design, combined with the unique nature of bamboo as a raw material, we can explore the design with modern sense.

Not only retains the natural texture and texture of bamboo itself, but also gives the packaging more cultural connotation and artistic value through creative design and exquisite craftsmanship. Cleverly using the flexibility and plasticity of bamboo to create different shapes and unique packaging containers, so that bamboo wine packaging has become a beautiful work of art. Bamboo was treated with special technology.

As a part of ancient Chinese culture, bamboo is widely used in making various wine containers because of its unique physical characteristics and natural beauty. These traditional bamboo wine containers not only reflect the wisdom and creativity of the ancient Chinese people, but also carry rich cultural connotations and historical values.

With the emphasis on traditional culture and the pursuit of environmental protection and sustainable development, bamboo wine container design has gradually attracted attention. A growing number of scholars and designers have begun to draw inspiration from ancient craft knowledge and apply it to the design of modern bamboo wine containers.

With the increasing popularity of the concept of environmental protection, the sustainable development of bamboo wine containers has been widely concerned. As a renewable resource, bamboo's environmental protection and sustainability provide a broad space for the future development of bamboo wine containers. Many suggestions have been put forward in the research literature on how to improve the durability of bamboo wine containers and reduce resource waste and environmental pollution through design

Modern design concept emphasizes innovation, the pursuit of uniqueness and novelty. At the same time, it also focuses on humanistic care, emphasizing that design should respect people's needs, emotions and cultural backgrounds. In addition, with the increasing awareness of environmental protection, sustainable development has also become an important part of modern design concepts.

People's pursuit of environmental protection, healthy life and new understanding of traditional culture, bamboo wine set as a green product with unique charm, the market demand is growing.

Rich market segments: bamboo wine set including wine glasses, wine bottles, wine POTS and other products, to meet the individual needs of different consumers.

On the basis of retaining the traditional bamboo weaving, bamboo carving and other crafts, the design is integrated into modern design concepts, so that the product has both a simple charm and modern aesthetic.

In addition to traditional bamboo, some designers have also tried to apply new bamboo materials such as bamboo fiber and bamboo charcoal to the design of wine sets, enriching the material selection of products.

The production process has both traditional handmade and modern mechanical production, which ensures the quality and output of the products.

With the continuous progress of science and technology, bamboo processing technology, surface treatment technology and so on are also constantly improving, so that the quality of bamboo wine set has been further improved.

As a green product, its production and use process has less impact on the environment, in line with the current social requirements for environmental protection and sustainable development.

Renewable resources: Bamboo, as a fast-growing and renewable resource, provides a steady stream of raw materials for the production of bamboo wine sets.

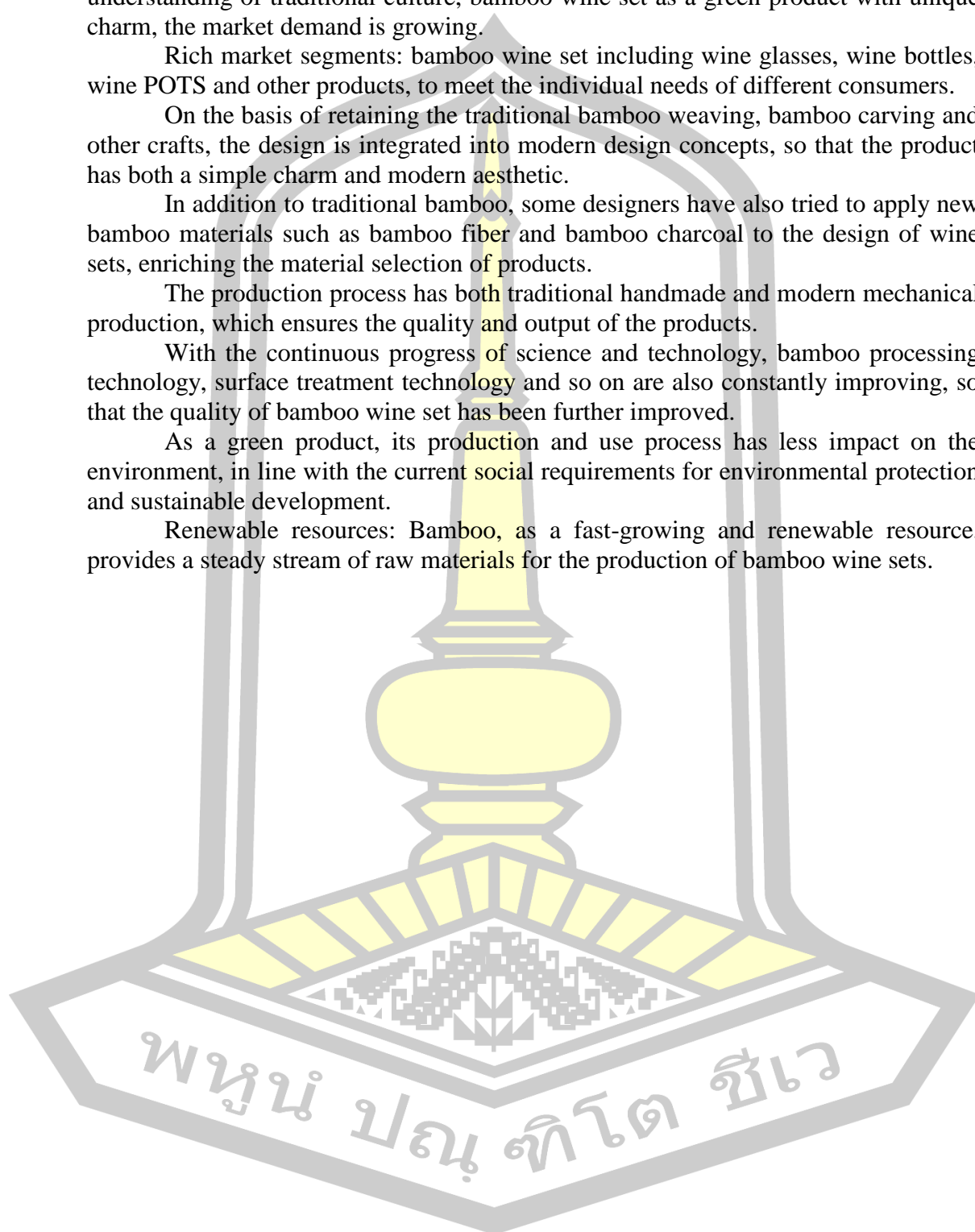

## CHAPTER III

### The wisdom of local wine packaging production

The deep culture of Lingnan makes the packaging of bamboo wine set in this region very distinctive in details. Use engraving, painting, etc.(Xiao Jiumei 2015)

We can learn from some traditional processes, such as using the method of wire fitting to wear these good materials together, which will appear more primitive, elegant and artistic.(Cai Songhua 2012)

The design practice of wine-warming utensils is guided by the idea of simple, independent, practical and beneficial creation. The design is analyzed from the design elements of simple shape, bright color, safe material, diverse use, reasonable structure and comfortable operation, and the situation of users using wine-warming utensils is analyzed by questionnaire survey and scenario. (Kong Huanxing 2023)

#### 3.1.Development of production

##### 3.1.1 The beginning of packaging production :

As early as 2000 years ago in the Qin Dynasty, bamboo began to grow and use bamboo. Through 2000 years of time, time change, time flow, hard-working and intelligent people made bamboo into a frame, box, so that bamboo really became a part of people's lives, but also slowly gave birth to characteristics.

Guangxi, an area rich in bamboo resources and inhabited by many ethnic groups, has nurtured a unique bamboo craft culture. With its exquisite craftsmanship, unique style and profound cultural connotation, Guangxi bamboo craft has become an important part of the excellent traditional culture of the Chinese nation. The purpose of this paper is to discuss the origin and development of bamboo craft in Guangxi, in order to provide useful reference for inheriting and carrying forward this excellent culture and promoting regional economic development.

Guangxi is located in the south of China, the climate is warm and humid, suitable for bamboo growth. There are many varieties of bamboo and abundant resources in Guangxi, which provide unique conditions for the development of bamboo craft. The bamboo forest in Guangxi has a wide area and wide distribution, which provides sufficient raw materials for the development of bamboo craft.

Guangxi bamboo craft has a long history, which can be traced back to ancient times. According to historical records, as early as the Han Dynasty, the bamboo weaving technology in Guangxi has been quite developed. In the Ming and Qing dynasties, Guangxi bamboo craft reached its heyday and formed a unique style and skill. In history, the inheritance and development of bamboo craft in Guangxi have been affected by multiple factors such as geographical environment, economic conditions and cultural atmosphere.

Guangxi is an area inhabited by many ethnic groups, and each ethnic group has its unique skills and inheritance experience in bamboo weaving and bamboo carving. For example, the Zhuang people's bamboo weaving is highly skilled and is famous for its unique weaving method and pattern design; The bamboo carving

technique of Yao nationality is favored by people for its exquisite carving skills and unique style. These traditional national cultures have injected rich connotation and vitality into the development of bamboo craft in Guangxi.

The bamboo craft in Guangxi is widely used in the production of daily necessities. Guangxi people skillfully use bamboo resources to make a variety of daily necessities. These bamboo products are not only practical, but also have unique artistic aesthetic value, which reflects the deep understanding and utilization ability of Guangxi people on bamboo.

Bamboo carving, also known as bamboo carving, is the carving of different characters and decorative patterns on bamboo products, or the use of bamboo roots to carve out a variety of ornaments. Bamboo carving can be divided into Yang carving and Yin carving, which can be traced back to ancient stone carving, ancient pottery inscriptions of primitive society and oracle bone inscriptions of the Shang Dynasty. In the Qin and Han Dynasties, in addition to the technique of intaglio carving, the technique of Yang carving also began to appear as decorative patterns. Of course, Yang carving flourished in the Tang Dynasty, and its carving techniques were dominant.

Bamboo carving art not only has a long history, but also a tortuous course, the people engaged in bamboo carving from the early "writers" and "Qing visitors", gradually changed into full-time bamboo carving artists. With the passage of time, bamboo carving techniques have also changed from the traditional Jinling bamboo carving, Jiading bamboo carving and other schools into a variety of schools and different techniques today, each with its own unique characteristics. Bamboo carving is a kind of carving technology which is formed under the accumulation of traditional bamboo carving, with new carving materials. The "new" of carving materials means that the materials used in carving are not traditional bamboo materials, but abandoned old coal bamboo. Coal bamboo, also known as smoked bamboo, is a common building material in rural kitchens in minority mountainous areas. It is commonly used as a bearing pendant in rural kitchens. Because it has been smoked by firewood and coal for a long time, it naturally forms an oily protective film and skin color such as bordeaux, purple and copper red, emitting a warm luster. At the same time, because of long-term smoking and roasting, coal bamboo has a certain ability to prevent insects and moisture, and is not easy to crack in dry areas, which is easier to preserve than traditional bamboo. Bamboo carving not only turns coal bamboo waste into treasure, but also makes reasonable use of its unique color, which distinguishes bamboo carving from traditional bamboo carving forms in appearance.

### 3.1.2 Past packaging production :

During the Spring and Autumn Period, the utilization of bamboo expanded, bamboo gradually developed like a technology, and the smell became stronger and stronger. Chu weaving technology is also very developed during the Warring States period, unearthed are: bamboo basket, bamboo basket, bamboo basket.

Guangxi bamboo art has a long history and a long history. As early as the Han Dynasty, the bamboo weaving technology in Guangxi has been quite developed. During the Southern and Northern Dynasties, bamboo craft of a certain scale and influence had been formed. During the Ming and Qing Dynasties, the bamboo craft in

Guangxi developed to its heyday, and the bamboo craft was constantly innovated, forming the Guangxi bamboo craft school with its unique style and skills.

In the middle of the Ming Dynasty, the use was further expanded, and more and more attention was paid to creating many high-grade bamboo vessels. For example, a painting box for painting and calligraphy, a small round box for jewelry, and a large round box for food.

The combination of bamboo craft and lacquer craft in the Ming and Qing dynasties created a lot of bamboo art, such as a painting box for collecting calligraphy and painting, various jewelry and powder boxes, and food boxes for storing food. Painted bamboo woven round box is a bamboo lunch box commonly used by officials in Ming Dynasty. These classic bamboo crafts have been passed down to modern times. After the Qianlong period of the Qing Dynasty, the traditional bamboo craft was fully developed, and the traditional bamboo products were more widely used in production and life, and the traditional bamboo products appeared in the daily use of bamboo tea tables, tea tables, table cabinets. From the pre-Qin period to 2500 years in modern times, bamboo products in China continued to expand to all fields of production and life, and the varieties were all-encompassing.

In history, bamboo weaving equipment was one of the important local light industrial products. According to the historical records of Sanjiang County, during the Republic of China period, Sanjiang bamboo weaving equipment was one of the important light industrial products in Sanjiang County.

In the early period, the bamboo process in Guangxi was mainly based on the self-sufficient production model of bamboo industry. Before the 1950s, bamboo craft in Guangxi was mainly based on the self-sufficient production mode of the people to meet the daily needs of the local people. In 1956, bamboo cooperatives began to be established in some areas, such as the establishment of bamboo cooperatives in Guyi Town Street, Sanjiang County, mainly producing bamboo baskets, bamboo ropes, bamboo strips, etc.

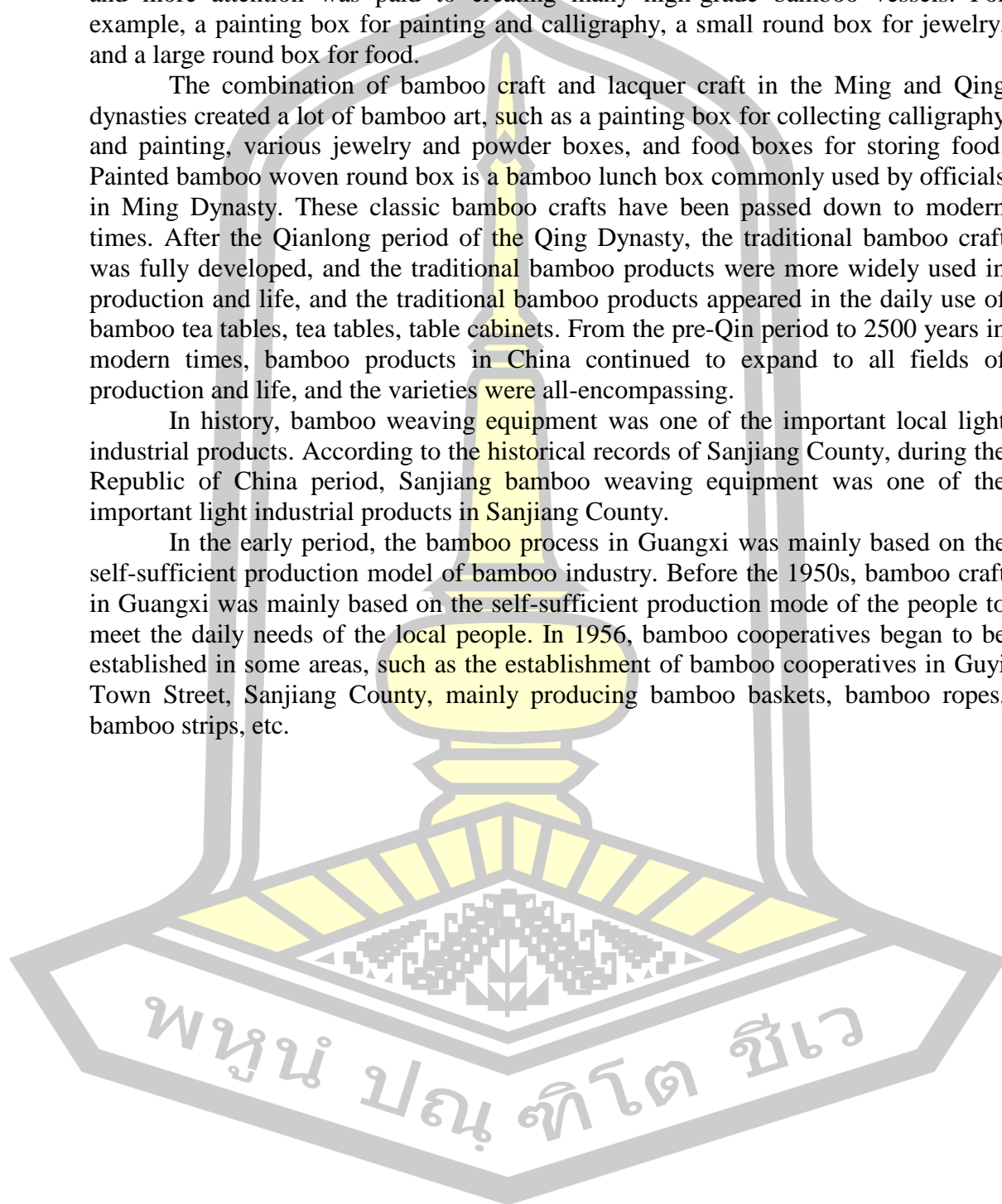

By the 1980s and 1990s, Guangxi bamboo products had become one of the bulk commodities and occupied an important position in the market.

In the past, Guangxi bamboo wine set was mainly used to meet the needs of People's Daily life, such as wine set, drinking set and so on. In festivals, family gatherings and other occasions, bamboo wine utensils are indispensable supplies.

Bamboo processing mainly relies on traditional manual methods. The craftsmen will choose bamboo with a moderate growth age and no diseases and pests, and then cut, remove leaves, peel and clean it into raw materials suitable for making wine sets.

In the past, the production of bamboo wine sets in Guangxi was mainly based on family workshops and small factories, and the output was relatively small. However, with the progress of market demand and technology, the production scale of bamboo wine sets has gradually expanded, and the output has also increased.

As we all know, bamboo carving techniques are very diverse with the development of The Times and technological innovation. Due to the uniqueness of the old coal bamboo carving materials, the main use of flat carving, relief carving, round carving, transparent carving four carving methods, the following brief introduction:

**Carve flat.** It is to carry out flat creation, gravure as the main engraving method, can also be called gravure engraving method. And the carving is divided into line carving, shallow carving, deep carving three ways.

**Shallow carving:** In the carving creation, according to the needs of the picture, with a thin knife carving, often need to use highlights to see the path of the knife marks, so at the same time, but also to highlight the meaning of the picture, verve, very test the sculptor's ability to control.

**Deep:** Compared with the shallow carving method, the knife is carried out with a thick knife, and the concave carving of the knife can be seen without the help of highlights. Deep and shallow carving is often a distant echo, deep needs to set off shallow carving, and shallow and deep, the appropriate combination of rich changes in plane carving. A relief. Yang eagle, also known as convex eagle. Relief is also divided into shallow relief, deep relief and green relief three types.

**Bas-relief:** is to use a knife to carve the four sides of the painted picture, the prominent part is to achieve the picture, this method is positive engraving. The carved parts around the painting can be smoothed with a knife to form a smooth shape; It can also create a variety of different texture effects, such as the use of light and shadow reflection of the ups and downs, irregular dots, hemp leaf patterns and other decorative effects, reflecting the diversity of a carving method.

**Deep relief:** Also known as high relief, it is the use of engraved to deal with the prominent part of the picture, more obvious, the picture is higher than that. This technique is generally used in landscape painting of trees, pavilions and other bamboo forest performance. **Green relief:** Since the traditional bamboo carving materials are mostly green bamboo, carving is to retain a thin layer of green skin on the surface of bamboo, remove the bamboo green outside the pattern, reveal the bamboo muscle under the bamboo green, and highlight the outstanding part of the work with the contrast of colors, so it is called "green relief". The use of coal and bamboo carving can also become a kind of "color relief", because of the characteristics of coal and bamboo, bamboo color is richer, bamboo skin color is also relatively heavy, while the

color is prominent, it can also reflect the deeper meaning of the work, expressing the traditional handicraft with the development of The Times and accumulated cultural heritage. The depth of the carving. It can also be called hollow carving method, most of the excess parts of the picture are completely carved, the use of "have" and "nothing" to reflect the three-dimensional and hierarchical sense of the work, but also retain a very shallow bamboo green, the use of light and shadow effect can deepen the sense of space of the work. This carving technique is mostly made together with flat carving, and the retained bamboo green part can also be processed with different textures according to the pattern requirements, making the picture more lifelike. Round sculpture. Another popular way of round carving is three-dimensional carving. According to the author's carving ideas, it is a carving technique presented by the choice of materials. In the process of engraving, the author needs to make a bold choice of materials, retain the useful parts of the creative picture, discard the useless parts or reduce the use of parts. Carving artists often need to have deep carving experience and subjective aesthetic choice of the picture. The above four types of bamboo carving techniques, although different, but interrelated. Especially in the old coal bamboo carving, due to the uniqueness of the material, bamboo after 20 to 50 years of fireworks baking, texture, structure, fiber have changed, coupled with this bamboo was originally used by farmers as building materials, bamboo itself will inevitably be damaged, resulting in mutilation. Therefore, in bamboo carving, the biggest difficulty is that we can not actively choose the material, some damaged bamboo can only be abandoned, and the bamboo that can be carved can only be designed and carved according to the shape of the material itself. In the process of design, bamboo carving must use patterns to cover up the damaged part and retain the usable skin color part, so that many modern factors can not appear in the design picture, which is very different from the development of traditional bamboo carving. In the process of carving, a single school, or a certain technique can no longer meet the requirements of bamboo carving, but also can combine different carving techniques to show bamboo carving, can be applied more bold, more extensive carving techniques. Local use of round carving, flat carving and other techniques, local can also integrate a variety of carving techniques, so that the picture more rich and wonderful. Therefore, in the process of bamboo carving, there is no need to consider a certain carving technique for a certain place of bamboo, but in order to better reflect the distance, level and different textures brought by bamboo carving, artfully combine different carving techniques. It is worth mentioning that on the smoked coal bamboo for a long time, it is not difficult to find the traces of years. Some bamboo leaves are difficult to remove oil stains, forming bamboo itself has a unique pattern; Some bamboos have a natural crack texture. Among them, the large area and relatively complete natural open piece, with the unique color of bamboo itself, is itself a magical process of nature, does not need any artificial carving technology to decorate, it has the beauty of texture, only need appropriate cutting, it is particularly suitable as a handle piece. And with the change of playing time, the color of bamboo skin and open grain will become thicker and more ornamental. This kind of bamboo ware that is "carved" by nature is also difficult to have in other bamboo carvings, and is another characteristic of bamboo carvings.

In the past, Guangxi bamboo craft production has a long historical tradition and exquisite manual skills, but the product types and production methods are

relatively limited, and the industrial scale and market influence are limited. However, with the support and protection of the government and all walks of life, the inheritance and development of bamboo craft in Guangxi has been valued and promoted.

### 3.1.3 Today's packaging production :

China has 105 million mu of bamboo forests, accounting for about a quarter of the world's total. Guangxi bamboo forest area of about 7 million mu, accounting for about 5.5% of the country, in the country's provinces (municipalities, autonomous regions) in the top.

Abundant bamboo resources provide sufficient raw materials for the development of bamboo industry in Guangxi.

There are many kinds of bamboo handicrafts, including but not limited to bamboo wine sets, bamboo woven storage baskets, bamboo woven handicrafts, etc. These products not only have practical value, but also contain profound cultural connotation. The production of Guangxi bamboo wine set is particularly outstanding, and its exquisite craft and unique style are welcomed by the market. Using these skills to make a variety of bamboo woven crafts, such as kettles, teacups, flower baskets, curtains, etc., these crafts not only increased income, but also further promoted the development of bamboo industry.

With people's pursuit of environmental protection, green and healthy life, bamboo wine utensils are gradually favored by the market as a kind of environmental protection and healthy drinking utensils.

Modern Guangxi bamboo wine set product types are more diversified, in addition to the traditional bamboo cylinder wine, but also developed bamboo wine glasses, bamboo wine bottles and other styles. These wine sets not only retain the charm of traditional bamboo wine, but also integrate modern design elements to meet the needs of different consumers.

With the popularization of the Internet and the development of e-commerce, the market scale of Guangxi bamboo wine set is constantly expanding. These wine sets began to go to the national and even global market, and the brand influence gradually increased. At the same time, the government and enterprises have also increased their support for the bamboo and wine industry, promoting the further development of the industry.

Modern Guangxi bamboo wine sets pay more attention to quality control in the production process. Through strict selection of materials, exquisite technology and strict quality testing, we ensure that every product meets high quality standards. In addition, some enterprises have also introduced advanced production management systems and quality control systems, further improving the quality and competitiveness of products.

Innovation and development In order to meet the market demand and the diversified needs of consumers, Guangxi bamboo and wine industry continues to innovate and develop. Some enterprises began to try to combine traditional bamboo wine sets with modern design elements to create bamboo wine sets with a sense of The Times and fashion. At the same time, some enterprises have also launched customization services, according to the individual needs of consumers to customize exclusive bamboo wine products.

Guangxi bamboo wine set production scale gradually expanded, the output value increased steadily. However, the specific output value data needs to be understood specifically based on the latest industry reports or statistics.

Bamboo artisans have accumulated rich experience and skills through generations of inheritance. In the modern bamboo wine packaging production, the traditional skills were further excavated and inherited, creating the traditional charm and modern bamboo wine packaging.

Selection and efficient utilization of bamboo. The southwest region has unique bamboo forest resources, which provides abundant raw materials for bamboo wine packaging production. Local producers have carefully selected high-quality bamboo with clear, strong texture as packaging materials.

The implementation and practice of environmental protection concept. In modern society, environmental protection has become an important value and development trend.

The past and present of bamboo craft production in Guangxi are closely related. The long history and skill inheritance provide a solid foundation for the bamboo craft production in Guangxi. The development of industrialization, product diversification and market expansion, technological innovation and policy support have promoted the further development of Guangxi bamboo craft industry. In the future, the bamboo craft industry in Guangxi is expected to continue to maintain a rapid growth momentum and make greater contributions to local economic development and cultural inheritance.

### **3.2 Production process**

#### **3.2.1 Bamboo selection :**

In the mountainous area of Guangxi, the rock exposure degree is high, the surface permeability is strong, the water storage performance is low, and the growth environment difference is obvious, which increases the difficulty of bamboo growth. Therefore, in view of this environmental feature, relevant departments combined with years of practical experience, bamboo cultivation and forest protection in Guangxi region have carried out in-depth research.

Choose varieties scientifically. The selection of bamboo varieties should follow the principle of adapting to the local environment and adapting to the characteristics of bamboo. In most areas of Guangxi, the soil layer thickness is different, the soil cover is not connected, and the water storage performance is poor, so the varieties with strong drought resistance, high barren resistance, high bamboo shoot yield and market demand should be selected, among which the Hung silk bamboo and flower hung silk bamboo are the main varieties. Secondly, the scientific selection and preparation of land. The survival rate of bamboo is mainly directly related to temperature and water, and it is necessary to choose the season when the temperature is warm and the bamboo shoots easily. Under normal circumstances, early February is the best time to grow new branches and leaves. The atmospheric precipitation is the main source of water in Guangxi, so the afforestation areas should be selected before and after rainy weather according to the rainfall conditions. The afforestation density was calculated according to the soil and bamboo species in each

area. Generally in fertile soil areas, bamboo root growth extends, bamboo plant height, bamboo cluster development needs space, should be thin afforestation. In poor soil areas, bamboo root development will be hindered, bamboo plants are small, bamboo cluster development needs little space, should be intensive afforestation. Large bamboo varieties should be thinly planted and medium varieties densely planted.

The production of bamboo wine containers begins with the selection of bamboo. High-quality bamboo should have the following conditions:

**Bamboo age:** Generally choose to grow 3-5 years of bamboo, at this time bamboo material tough, clear texture, suitable for processing.

**Diameter:** Bamboo with a diameter of 8-12 cm not only ensures the volume of the container, but also facilitates processing and carving.

**Number of sections:** Bamboo with fewer sections and longer pitch makes the container more flat and beautiful after processing.

According to the standard, as raw material. Not only the material is excellent, but also has a high ornamental value.

In the vast territory of our country, there are many different kinds of bamboos growing. In fact, not just one of these bamboos can be used as materials and it is more suitable for them among the complicated and intricate species of bamboos.

Green hedge bamboo, produced in Guangxi, straight and smooth, elastic, used in common products. Green bark bamboo. Origin Guangdong, Guangxi. Compared with other bamboos, the growth rate is fast, the material is soft and resilient, and it is a more common material in the south

Guangxi is rich in bamboo resources, among which bamboo has become the first choice for making bamboo wine sets because of its fast growth, tough material and clear texture.

Choose bamboo grown in a natural environment, such as the bamboo in Maoershan National Nature Reserve, which grows under high-quality natural conditions and is rich in nutrients, providing sufficient nutrients for the fermentation of wine.

Bamboo age is generally selected to grow 3-5 years of bamboo, at this time the bamboo material is tough, clear texture, suitable for processing.

In the process of material selection, bamboo that grows robustly and is free of pests and diseases is selected to ensure its good toughness and beauty. According to the specific requirements of packaging design, choose different thickness and length of bamboo to meet different packaging needs.

### 3.2.2 Cutting and preparation stage :

Cut bamboo during the mature season to maintain the freshness of the bamboo. After logging, the bamboo should be transported to the processing site in time to avoid drying and cracking caused by long-term exposure to the sun.

Wash the bamboo to remove dirt and eggs from the surface. Then airing or drying to the appropriate moisture content, generally 10%-15%, in order to facilitate subsequent processing and preservation.

**Cutting tools:** commonly used cutting tools are saws, knives, axes and so on. Among them, the saw is the most commonly used tool, and different types of hand saw and electric saw can be selected according to needs.

**Whole section cutting:** The bamboo is cut in whole section according to the required length. Pay attention to keep the cutting surface flat and smooth, so as to facilitate subsequent processing and assembly.

**Ring cutting:** For bamboo that needs to be made into a ring container, ring cutting is required. You can cut with a professional ring cutter or by hand. During the cutting process, pay attention to keeping the cutting surface rounded and smooth.

**Oblique cutting:** In order to increase the beauty and stability of the container, it is sometimes necessary to diagonal cutting of bamboo. The miter Angle is generally determined according to the design needs, and the stability and speed consistency of the tool should be maintained when cutting.

**Cutting accuracy:** Cutting accuracy is the key to making high quality bamboo wine containers. In the cutting process, accurate measuring tools should be used for dimensional measurement and positioning to ensure the precision and accuracy of cutting.

**Grinding:** There may be burrs and unevenness on the surface of the cut bamboo, which needs to be polished. You can use sandpaper, sander and other tools to polish, so that the surface of the bamboo becomes smooth and delicate.

**Anti-corrosion treatment:** In order to prevent the bamboo from being damp, mildew and decay during use, anti-corrosion treatment is required. Common anti-corrosion methods include soaking, brushing and so on. Appropriate preservatives can be selected for treatment to ensure the durability and beauty of the bamboo.

**Detail treatment:** In the preparation process of bamboo, some details need to be processed. For example, remove the raised part of the bamboo joint, repair the cracks and damage on the surface of the bamboo. These details can further enhance the quality and ornamental value of the container.

The selected bamboo is cut according to the size requirements of the package design, and the incision is polished to ensure that the cutting surface is smooth and without burrs. At the same time, the bamboo is cleaned and disinfected to ensure the hygiene and quality of the bamboo.

**Avoid direct sunlight:** Prolonged exposure to sunlight can cause discoloration and cracking of the bamboo, so the container should be placed in a cool and ventilated place.

**Keep dry:** Bamboo is prone to moisture and mildew, so keep a dry environment when using and storing. If the container is not used for a long time, it can be wiped clean with a dry cloth and placed in a dry and ventilated place.

**Avoid pressure and collision:** bamboo wine containers are more fragile and should be avoided by external forces such as pressure and collision. Handle with care during handling and storage to avoid damage.

**Regular cleaning:** After a period of use, the inside of the container may accumulate some dirt and bacteria. Therefore, it is necessary to regularly clean the inside and outside of the container to ensure health and safety.

When the base wine is injected into the bamboo tube, the minimally invasive high-pressure technology is used to ensure that the base wine can fully penetrate into the fiber of the bamboo, while not damaging the structure of the bamboo, maintaining its original quality and uniqueness.

The secondary fermentation process in the bamboo tube makes the base wine fully integrated with the bamboo, forming a unique bamboo aroma and taste, further improving the quality and uniqueness of the bamboo wine set.

Avoid direct sunlight and high temperature During storage, avoid direct sunlight and high temperature to prevent discoloration and cracking of bamboo.

The storage environment should be kept dry to avoid excessive humidity leading to mildew or deterioration of bamboo.

The making of bamboo wine containers is a delicate and complicated work, which requires certain skills and experience. Through the introduction of this article, I believe readers have a deeper understanding of the cutting and preparation process of bamboo wine containers. In the actual production process, it is also necessary to adjust and improve according to the specific situation, and constantly improve the quality and artistic value of the product.

### 3.2.3 Production stage :

There are many kinds of bamboo wine utensils in Guangxi, including bamboo wine pot, bamboo wine cup, bamboo wine spoon, etc. These products not only have practical value, but also have artistic and cultural properties.

Bamboo wine set with its unique texture, color and texture, as well as environmental protection, health characteristics, favored by consumers.

In addition to great practical value, bamboo wine set also has a very long historical connotation, but also a symbol of ancient culture, very worthy of inheritance, so that this art can be endless, handed down to future generations. In the long and wonderful historical process, many artworks are derived from the lives of ordinary people, and art comes from life. When bamboo art first appeared, it was more used for daily life and agricultural production needs. After these needs appeared, it was gradually used as a daily item. In order to beautify the building, the hand-made art appeared in the public's vision, which brought us, in addition to its practicality, more is the impact on folk art. From bamboo art, we can deeply feel the ancient people's concept of life - that is, the practicality of products. The special crafts formed by bamboo wine set, each with its own cultural connotation, its manufacturing process, its symbol, all of them represent the ancient people's yearning for a better life, for the love of farming life, these represent people's yearning for a better life. It can be said that bamboo wine set is not only handicrafts, but also folk culture, but the most fundamental, it is the product of the daily life of the ancient people, it comes from life, sublimation in life, is a colorful treasure in the traditional manual art.

Crafts and national characteristics show the unique charm of Guangxi bamboo culture. The following is a clear summary and classification of the finished products of Guangxi bamboo wine set: Bamboo wine: Guangxi bamboo wine is one of the most well-known products. Bamboo tube wine is selected in the bamboo or bamboo youth in the middle of 2-3 segments of the bamboo body directly injected with high-quality Maomao-style liquor, after 2 to 9 months of natural brewing and absorption of natural dew essence, in order to brew bamboo Lintian dew wine, which is commonly known as bamboo tube wine. This kind of wine has the effect of relaxing tendons and activating collaterals, improving immunity, softening blood vessels, anti-aging, anti-fatigue and prolonging life.

Bamboo wine glasses: Guangxi bamboo wine glasses attract consumers with its unique material and shape. The wine glass is made of high-quality bamboo, which

has been finely polished and carved, showing a unique artistic style. The surface of the glass is delicate and smooth, feel comfortable, and use is both environmentally friendly and healthy.

**Bamboo wine bottle:** Guangxi bamboo wine bottle is not only practical, but also a beautiful work of art. The wine bottle is made of whole bamboo, which is cut, polished, carved and other processes to form a unique shape and texture. The surface of the bottle can also be customized according to customer needs, such as carved patterns, text, etc., which increases the personalized elements of the bottle.

**Material selection:** The production of bamboo wine set in Guangxi selects local high-quality bamboo as raw materials, such as golden bamboo, ink bamboo, etc. These bamboos have short growth cycle, high yield and good quality, which provide sufficient raw materials for the production of bamboo wine sets.

**Production process:** The production process of bamboo wine set includes bamboo selection, cutting, grinding, carving, grinding and other processes. Among them, carving is one of the most critical links in the production of bamboo wine sets. Craftsmen use exquisite carving skills to carve bamboo into various shapes and patterns, making bamboo wine sets more artistic and ornamental.

**Quality control:** Guangxi bamboo wine set production pay attention to quality control. From the selection of raw materials to the production process, there are strict quality inspection standards and control measures.

**Bamboo storage baskets and baskets:** These products have a wide range of uses, including tea, storage baskets and so on. For example, the bamboo woven storage baskets and baskets produced by Yiqiang Bamboo basket Craft Factory in Xinfeng Village, Shuiming Town, Bobai County, are popular in the market because of their fine hand-made and practical.

**Bamboo gift box and packaging:** The Mid-Autumn Festival hand-held bamboo basket, zongzi basket, etc. produced by Guangxi Bamboo weaving Craft factory, is not only beautiful in appearance, but also practical, which is a good gift for the festival.

**Bamboo decorations:** such as bamboo woven small lanterns, triangle Zongzi style ancient sachet sachet, etc., these products with its unique shape and exquisite craft, become a popular choice for home decoration and hanging decorations.

**Bamboo woven dustpan and sieve:** These products are mainly used in kitchen and agricultural production, such as the dustpan and sieve produced by Fenghuang Bamboo boutique in Yandun Town, Lingshan County, which are durable and environmentally friendly.

**Bamboo furniture:** such as bamboo chairs, bamboo beds, etc., some manufacturers in Guangxi use the hard and durable characteristics of bamboo to make beautiful and practical bamboo furniture.

**Floral bamboo hat:** Floral bamboo hat is a major feature of Guangxi bamboo craft, its production skills are exquisite, colorful patterns. For example, the flower bamboo hat produced by Shengan craft factory in Pingshan Town, Pingnan County, the top of the hat is woven into a small hole shaped like a honeycomb eye, and the hat rim shows a black ring, which is exquisite.

**Bamboo boats:** Some manufacturers in Guangxi also produce children's DIY toys such as bamboo boats, which are both entertaining and can cultivate children's hands-on ability and creativity.

The finished products produced by bamboo craft in Guangxi are rich and diverse, covering many fields such as bamboo woven crafts, bamboo daily necessities and bamboo specialty products. These products are not only of practical value, but also full of artistic and cultural connotation, which fully demonstrates the unique charm of Guangxi bamboo culture and the exquisite skills of craftsmen.

In modern times, decorations and applications related to bamboo art can be seen everywhere. The application of bamboo craft in modern architectural design has gradually evolved from a craft means to a craft cultural phenomenon. There are more and more architectural designs with bamboo culture as the carrier, which can show the special regional cultural customs. For example, the bamboo is introduced into the original reinforced concrete construction design, and the natural architectural decoration design concept changes people's lives. For example, the bamboo structure pavilions in various local expo parks, their shape distribution is like a slow flowing river, with a strong sense of rhythm. Specifically speaking, bamboo weaving art in modern architecture furniture, ceramics, lamps and lanterns also have a wide range of applications, these bamboo weaving art products can not only make people feel relaxed and happy, there is a fresh in nature. It can also perfectly combine traditional culture with modern architecture. Can reflect the pursuit of art, but also innovative environmental protection. In fact, bamboo art in architecture is more as an ornament, there are many dazzling types of bamboo art ornaments, not only bamboo woven baskets, plates, bottles, MATS, fans, screens, etc., but also elegant and Linglong architectural artifacts, brilliant gods, birds, spirits and animals, exquisite traditional figures and so on. The roofs of these beautiful houses are just like the wings of a butterfly. The whole house is made of bamboo weaving art. The roof structure makes the house watertight during the rainy season. The little house is full of art and beauty.

Create both traditional charm and modern packaging. In the production process, the bamboo is processed into various shapes and patterns by a combination of hand weaving, forming a unique packaging appearance.

Guangxi bamboo wine set, with its unique craft and national characteristics, has won wide recognition and praise in the market. The finished products include bamboo tube wine, bamboo wine glasses, bamboo wine bottles, etc. Each product reflects the exquisite skills and unique creativity of the craftsmen. At the same time, with the constant change of consumer demand and the intensification of market competition, Guangxi bamboo wine set production enterprises are also constantly innovating and improving the production process, improving product quality and added value, in order to adapt to the development of the market and meet the needs of consumers.

พหุ ประโยชน์ ชั่ว

## CHAPTER IV

### Design and develop packaging for local smart bamboo wine

Combined with the modern wine set with the form innovation. This not only absorbs national culture, but also combines it with modern culture, reflecting the modern aesthetic characteristics of simplicity, fashion and generosity, but also cleverly integrates with traditional culture, which is realized in a convenient and simple life. (Li Yuchen 2020)

"Tools carry the way." The design includes a tray, a jug and a glass. This wine set is convenient for mass production on the assembly line and retains the manual traces of the wine set maker; It is not only convenient for people to use, but also reflects the independent spirit of the drinker. It not only reflects the designer's skilled use of wine materials, but also fully expresses the deep affection for the traditional culture of the motherland. (Pan Yu 2018)

The design concept of modern ceramic wine bottle can be built on the basis of regional culture, through the combination of modern product design ideas, to create regional culture ceramic wine bottles in line with the spirit of the new era. (Wei Zhan 2014)

#### 4.1 The production and design steps are as follows :

##### 4.1.1 Select materials

When choosing materials to make bamboo wine sets, we need to consider several factors to ensure that the final product is both beautiful and durable. The following are detailed selections and instructions on the materials for making bamboo wine sets according to the information in the reference article:

##### Selection of bamboo:

High-quality bamboo species are preferred to choose high-quality bamboo such as golden bamboo, bamboo and other strong growth, no insects, no cracks as raw materials. These bamboos usually have a moderate growth cycle, high yield and good quality, and are very suitable for making wine utensils.

**Bamboo Ripeness** Choose bamboo with moderate ripeness to ensure sufficient strength and toughness. Bamboo that is too young may not be strong enough, while bamboo that is too old may be brittle.

**Bamboo treatment: Cleaning treatment** Bamboo needs to be cleaned after picking to remove dirt and impurities from the surface.

**Drying and drying** After cleaning, bamboo needs to be dried in the sun to ensure that it is completely dry. Dried bamboo is easier to work with and less prone to deformation.

**Bamboo specifications and dimensions: Diameter and length** According to the design requirements of the wine, choose the appropriate diameter and length of bamboo. For example, the diameter of a bamboo glass is usually between 5-8 cm, and the length ranges from 30-40 cm.

**Internode length** For wine utensils that need to retain bamboo joints (such as bamboo wine POTS), special attention needs to be paid to the length and shape of the internode to ensure the beauty and practicality of the final product.

**Material sustainability:** Ecological Bamboo as a renewable resource has a high environmental value. The choice of bamboo as the production material of wine sets not only meets the requirements of sustainable development, but also helps to protect the ecological environment.

After proper maintenance, high-quality bamboo wine sets can be used for a long time and even passed on to future generations. This helps to reduce waste of resources and reduce environmental pollution.

The selection of materials is a crucial link, which directly determines the quality and uniqueness of the wine. Here are the key considerations when selecting materials, summarized in a clear, point-by-point manner:

**Preferred bamboo:** Bamboo with its fast growth, tough material, clear texture characteristics become the first choice for the production of bamboo wine.

**Bamboo age:** Choose bamboo that is 3-5 years old. At this time, the bamboo material is tough and fine, which can ensure the strength and durability of the wine set.

**Diameter and number of sections:** Bamboo with a diameter between 8 and 12 cm is more suitable for processing and carving.

After bamboo processing with fewer segments and longer pitch, the container is more smooth and beautiful.

Appearance and quality checks ensure that there are no obvious defects on the surface of the bamboo, such as cracks, wormholes, stains, etc.

Check the internal quality, for example, by tapping or shaking the bamboo to hear the sound to determine whether there is moth or hollow inside.

**Growth environment:** Choose bamboo growing in the natural environment, such as mountain areas, forests, etc., where the growth conditions of bamboo are superior and the quality is better.

**Environmental protection requirements:** Choose bamboo that meets environmental protection standards, such as raw bamboo without chemical treatment, to meet the needs of modern consumers for environmental protection.

During the transportation process, attention should be paid to protect the bamboo from damage and ensure the integrity of the material.

When stored, it should be placed in a ventilated and dry place, avoid direct sunlight and humidity, in order to maintain the quality of bamboo.

In the selection of bamboo, we should consider the principle of sustainable development, not to over-cut bamboo forest resources, to ensure the sustainable use of resources.

Choose the bamboo suitable for making wine sets, generally choose high-quality bamboo with good growth and no diseases and pests to ensure the quality of bamboo, with tough texture and smooth skin, which is very suitable for making wine sets.

When making bamboo wine set, the choice of material is very important. Quality bamboo, proper handling and proper size are all key factors in ensuring the quality and beauty of the final product. At the same time, the choice of bamboo as a production material also meets the requirements of environmental protection and sustainable development. By carefully selecting and treating bamboo, we can make bamboo wine sets that are both beautiful and durable, adding a natural and harmonious atmosphere to people's lives.

#### 4.1.2. Design and cutting

Designing bamboo wine set is a creative work that combines traditional craft with modern aesthetics. In the design process, we need to take into account the practicality, aesthetics and the combination of bamboo characteristics. The following is a detailed description of the design of bamboo wine set:

When designing bamboo wine sets, we must first clarify the core concept of design, that is, combine the natural properties and cultural symbols of bamboo, to create a practical and artistic wine set. At the same time, we should pay attention to the environmental protection of wine and reflect the concept of green life.

The selection of high-quality bamboo as the raw material for the wine set takes into account the short growth cycle and strong renewable characteristics of bamboo.

**Wine pot design:** wine pot as the main part of the wine set, its shape should reflect elegance and stability. Traditional bamboo tube shapes can be used, or modern design elements can be added, such as streamlined contours, simple lines, etc. At the same time, exquisite patterns and words can be carved or painted on the wine pot to increase its artistic value.

**Wine glass design:** The design of wine glasses should pay attention to comfort and aesthetics. Can use cylindrical, elliptical and other simple and generous shape, cup mouth slightly closed, easy to drink. In addition, you can carve or paint wine-related patterns or poems on the cup to add cultural atmosphere.

**Supporting design:** In addition to wine POTS and wine glasses, you can also design some supporting wine utensils, such as wine trays, wine spoons, etc. These matching wine sets can form a unified style with the main body wine sets to improve the overall aesthetic feeling.

**Tightness:** The tightness of the wine pot is very important, and it is necessary to design a reasonable sealing structure to ensure that the wine is not volatile or leaking. Bamboo plug, rubber pad and other sealing materials can be used.

**Non-slip:** The bottom of the glass can be designed with non-slip texture to increase stability and prevent sliding on the table.

**Portability:** Considering the carrying and storage needs of the wine set, it can be designed to be detachable, folded or packaged, which is convenient for users to carry and store.

**Color selection:** Bamboo itself has a natural green or yellow tone, which can be chosen to retain the primary color or be dyed according to the design needs. Color collocation should be harmonious and unified, avoid too fancy or dazzling.

**Decorative elements:** Some decorative elements can be added to the wine set, such as carving, painting, inlay, etc. These decorative elements should be coordinated with the overall design style, which can not only enhance the beauty of the wine set, but also increase its cultural connotation.

**Grinding treatment:** Fine grinding of bamboo to ensure smooth surface, no burrs, no defects.

**Anti-corrosion treatment:** The use of environmentally friendly non-toxic anti-corrosion coating for anti-corrosion treatment of wine, improve the service life.

**Drying treatment:** In the process of processing, the bamboo is properly dried to reduce deformation and cracking.

**Style and function:** According to the market demand and consumer preferences, design a variety of styles and functions of bamboo wine set, such as wine pot, wine glass, wine cylinder, etc.

Considering the natural characteristics and texture of bamboo, design patterns and decorations in harmony with them to enhance the uniqueness and artistic sense of the product.

**Size and specifications:** According to the use scenario and needs, determine the size and specifications of the product, such as height, diameter, capacity, etc.

Considering the portability and stability of the product, the design of reasonable size and specification.

**Drawings and models:** According to the design scheme, draw detailed product drawings, including plans, elevations and sections.

Make product models or samples for reference and adjustment in the actual production process.

**Bamboo selection and preparation:** Select high quality, non-moth, non-crack bamboo as raw materials.

Clean the bamboo, remove surface dirt and impurities, and ensure that the cutting surface is smooth and clean.

**Cutting equipment and tools:** Use professional bamboo cutting equipment and tools, such as saws, cutting machines, etc.

According to the product design and size requirements, choose the appropriate cutting equipment and tools.

**Cutting process:** The bamboo is precisely cut and cut according to the requirements of the product drawings and models.

Pay attention to keep the cutting surface flat and smooth to avoid defects such as burrs and cracks.

According to the need, the bamboo after cutting is polished and trimmed to improve the appearance quality and practicality of the product.

**Cutting precautions:** During the cutting process, ensure the safe use of equipment and tools to avoid accidents.

Pay attention to keep the working environment clean and ventilated to reduce the impact of dust and noise on staff.

For wine utensils that require special shape or structure, they can be treated by hand cutting or special processes to ensure the accuracy and beauty of the product.

The bamboo after cutting is cleaned and dried to avoid the impact of moisture and dirt on the quality of the product.

According to the need, the bamboo after cutting should be treated with anti-corrosion and anti-insect, so as to extend the service life of the product.

Turn ideas into sketches, using hand drawings. Each part of the bamboo wine set is described in detail in the sketch, including the overall outline, detailed features, etc.

The bamboo is cut and trimmed according to the specific needs of making wine utensils. Using a sharp knife or a professional cutting tool, cut the bamboo to the desired length and shape.

The design and cutting process of bamboo wine set is a complex process integrating creativity, technology and quality. Through fine design and precise cutting, ordinary bamboo can be transformed into a wine set with artistic value and

practical value. This is not only the inheritance and development of traditional crafts, but also a full use and display of local culture and natural resources.

#### 4.1.3. Perfect details and decoration

Bamboo wine set, as a combination of traditional and modern dining utensils, its history can be traced back to ancient times. Bamboo is natural, environmentally friendly, and has a unique texture and texture, making bamboo wine sets popular in the catering industry. Bamboo wine set is not only practical, but also an important carrier to display catering culture because of its unique artistic temperament.

The design of bamboo wine set pays attention to the combination of natural charm and artistic temperament. Drawing inspiration from nature, the designers incorporated the natural texture and form of bamboo into the design, making the wine set present a simple but elegant aesthetic. At the same time, through carving, painting and other processes, to add rich artistic elements to the wine set, making it more ornamental and collection value.

Make a small hole near the knot of the bamboo and use a special tool to inject the wine into the inside of the bamboo. In this process, the location, size and depth of the holes need to be precisely controlled to ensure that the wine can be smoothly injected and sealed. When pouring wine, it is also necessary to ensure the quality of the wine, usually using high-quality liquor.

After drinking, it is necessary to use a small stick or toothpick and other tools to seal the holes to prevent the leakage of the wine and the invasion of bacteria. Then, the bamboo wine is placed in a cool and ventilated place for preservation, so that the wine and bamboo mature together, so that the wine into the fragrance of bamboo.

**Packaging and storage:** Clean and dry the bamboo wine set after production. Use appropriate packaging materials to prevent damage during transportation and storage.

Indicate the use instructions and maintenance methods, so that users can use and maintain the wine properly.

**Carving and decoration:** The decoration of bamboo wine sets in Guangxi is usually in the form of carving. Craftsmen use exquisite carving skills to carve out various patterns and characters on bamboo, such as mountains, flowers and birds, poems, etc., making the wine set more artistic and ornamental. At the same time, you can also wrap ribbons or silk scarves and other decorations on the outside of the wine set to increase its beauty.

According to the design sketch by adding patterns and elements on the surface of the wine can enrich the work, using different decorative techniques, such as carving, Mosaic, etc.

Decorative bamboo wine set is a delicate art work, which combines traditional craft with modern aesthetics, adding unique artistic charm and cultural value to the wine set.

Use a professional carving tool to carve on bamboo according to the design pattern.

The depth of carving should be moderate to avoid damaging the structure and strength of bamboo.

The sculpting lines should be smooth and delicate, showing the texture and texture of the bamboo.

**Color treatment:** Some Guangxi bamboo wine sets can use some color treatment methods in the production process, such as dyeing, painting, etc., to make the color of the wine sets more bright and beautiful to meet the needs of consumers for color.

**Personalized customization:** In order to meet the needs of different consumers, Guangxi bamboo wine set can also be customized. Consumers can choose the style, color, pattern, etc. of the wine set according to their own preferences and needs, so that the wine set is more personalized.

**Decorative details** Add anti-slip mat, protective cover and other accessories to the handle, spout and other key parts of the wine set to improve the comfort of use.

The bottom of the wine set adds a support structure to enhance stability.

Carving or painting on the wine set is in harmony with the main body to increase the artistic atmosphere.

The design of bamboo wine set pays attention to the combination of natural charm and artistic temperament. Drawing inspiration from nature, the designers incorporated the natural texture and form of bamboo into the design, making the wine set present a simple but elegant aesthetic. At the same time, through carving, painting and other processes, to add rich artistic elements to the wine set, making it more ornamental and collection value.

The pursuit of ultimate perfection in detail and decoration. Through fine carving and painting techniques, the bamboo wine set is created with originality. In the aspect of carving, he uses rich imagination and superb skills to carve out a variety of lifelike patterns and characters; In the aspect of painting, natural plant pigments are used to color, so that the color is more bright and lasting. These perfect details and decorations make the bamboo wine set not only practical value, but also a beautiful piece of art.

#### 4.1.4.Finished product disposal

The packaging of bamboo wine set should take into account the protection and aesthetics of the product. Common packaging materials include cardboard boxes, bamboo boxes or environmentally friendly plastic bags, with shockproof MATS and protective layers to ensure that the product is not damaged during transportation.

**Example:** A bamboo wine set brand uses bamboo box packaging, the box is equipped with special grooves and shock-proof pads, which not only shows the environmental characteristics of the product, but also ensures the safety of the product.

Clean the bamboo wine set to remove surface dirt and impurities.

The bamboo is dried or dried to reduce the moisture content to prevent deformation or mold during production.Prevent scratching or damage to the surface to prevent deformation or cracking.

#### 4.1.5.Inspection of finished product

Bamboo wine set is gradually favored by people for its unique material and style. Common bamboo wine utensils include wine glasses, wine bottles, wine POTS, etc., mainly used for holding and tasting wine. Bamboo wine set is characterized by its natural, environmental protection, beautiful appearance, and has a certain durability. Through fine processing, bamboo wine sets can show a unique texture and luster, adding a different elegance to wine tasting.

According to the final design, the finished bamboo wine set is made. conduct quality inspection of finished products to ensure compliance with design requirements and quality standards.

The inspection of finished product is the key link to ensure the quality of bamboo wine set. Through the inspection of the finished product, the quality problems that may exist in the production process can be found and eliminated in time to ensure that the product meets the design requirements and quality standards.

Appearance inspection (observation) whether the surface of the product is smooth, no cracks, no defects, and whether the color is uniform.

Dimensional measurement Accurate measurement of product dimensions to ensure compliance with design requirements.

Material identification Through observation and testing, verify that the quality of the bamboo used in the product meets the standard.

Functional test The sealing, load-bearing and other functions of the product are tested to ensure that the product can work normally during use.

It is of great significance to inspect the finished bamboo wine set to ensure product quality and meet customer demand.

4.2. Display design drawings and finished creations :

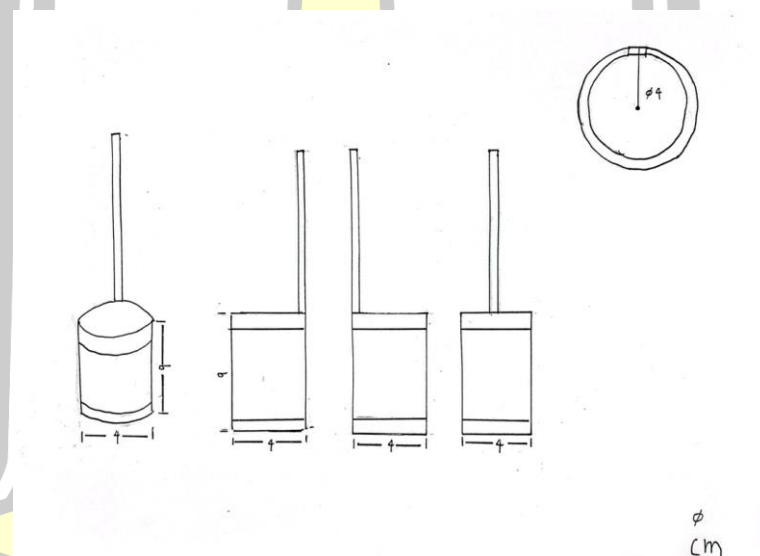

Figure 2

พหุ ประถมศึกษา ชีวะ



-Figure 3

Bamboo wine ladle is easy to preserve, cheap, and good for health, so the bamboo wine ladle and bamboo wine cup fusion.

**Design concept:** In the design, the use of both habits and aesthetics should be fully considered. When mixing bamboo wine ladle and bamboo wine glass, it should ensure the harmonious unity of functionality and aesthetics, while highlighting the natural texture and texture of bamboo.

**Integrated design:** Bamboo wine ladle and bamboo wine cup can be designed as a whole, and the body part of the wine cup is connected with the handle of the wine ladle to form a unique shape.

This design makes it easy to scoop the liquor from the wine jar or bottle and then pour it directly into the glass, without having to find or pick up the wine to scoop.

**Practicality:** In the design, it is necessary to ensure that the ladle function of the wine is good, and the capacity of the glass is moderate and easy to drink.

**Aesthetic:** Using the natural texture and color of bamboo, the design is simple and generous. At the same time, some patterns and words related to wine culture can be carved or painted on the wine ladle or glass to increase its cultural flavor and artistic value.

#### Material and process

**Material:** Choose hard texture, natural color, no insects, no cracks of high-quality bamboo as raw materials.

**Process:** In the production process, it is necessary to ensure that the cutting, polishing, engraving and other processes of wine ladling and wine glasses are fine in place to achieve both beautiful and practical effects.

#### Maintenance and cleaning

Excessive collision and friction should be avoided during the use of bamboo wine utensils so as not to damage the surface.

When cleaning, use a soft wet cloth to wipe, avoid using hard objects or chemical cleaners.

Store in a dry and ventilated place, away from direct sunlight and damp environment.

Cultural significance: The integration of bamboo wine ladle and bamboo wine glass not only reflects the practicality and beauty of bamboo wine set, but also carries profound cultural connotation. This design can be used as a cultural symbol to inherit and promote Chinese wine culture, and at the same time show the charm of Chinese traditional handicrafts to the world.

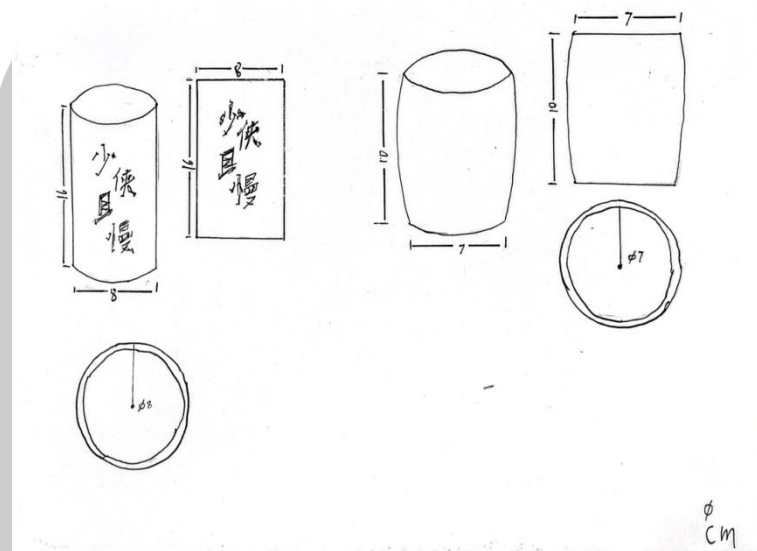

Figure 4



Figure 5

Where there are people, there are rivers and lakes, and the young people who have entered rivers and lakes pass by. Carved words on the bamboo wine cup, saying to it: "Young man wait, come in to drink a cup of wine and have a rest."

Carving characters on bamboo wine glasses, giving it a unique emotion and story, is a way to inherit and show Chinese wine culture. For the young people who have just entered the river, we can carve the following words on the bamboo wine cup to express our sincere invitation and blessing:

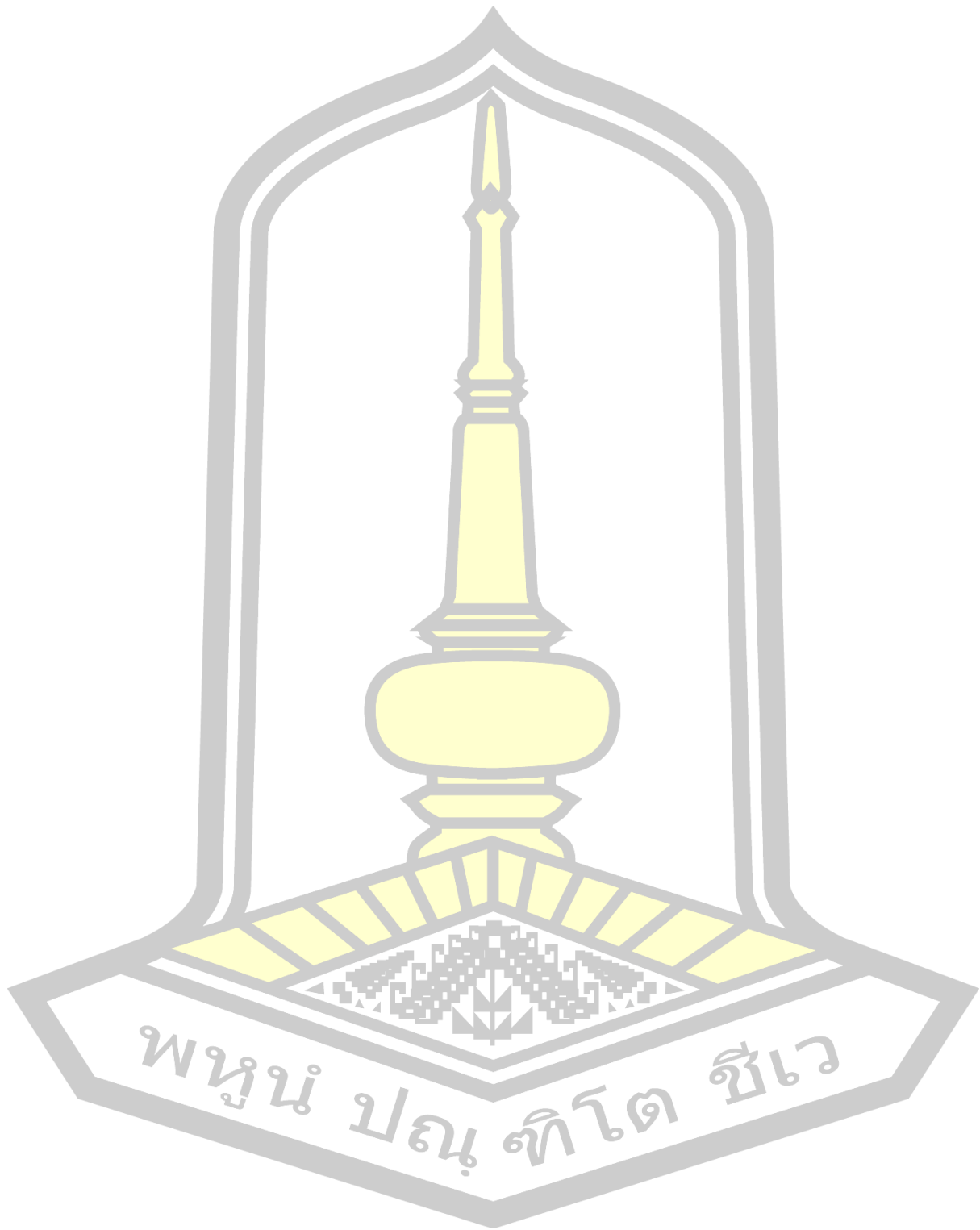

Young man, wait,  
 There is a long way to go.  
 A glass of bamboo wine,  
 Invite you for a drink and a rest.  
 May you have a bright future,  
 Brave the wind and waves, go forward.

This text contains several levels of meaning:

Sincere invitation: "Youth Wait" and "Invite you to drink together" both express respect and invitation to the teenager, hoping that he will stop to taste the bamboo wine.

Blessing and encouragement: "May you have a bright future, ride the wind and waves, and march forward" is a good wish for the young, hoping that he can achieve good achievements in the rivers and lakes, not afraid of difficulties, and march forward.

Cultural feelings: The whole paragraph integrates the romantic imagination of "Jianghu" and "Shaoxia" in traditional Chinese culture, and also shows the tradition of "drinking party friends" in wine culture.

When engraving, you can choose to use laser engraving or hand engraving. Laser engraving can accurately present the text, while hand engraving can more deeply reflect the feelings and skills of the craftsman. Either way, pay attention to the depth of the carving and the fluidity of the lines, ensuring that the text is both clearly recognized and integrated with the texture of the bamboo.

In addition, some patterns related to wine or rivers and lakes can also be carved in other parts of the bamboo wine cup, such as mountains, clouds, swords, etc., to further enhance the artistic atmosphere and cultural connotation of the wine cup.

Finally, when the young man picked up this cup of bamboo wine engraved with blessings and invitations, he could not only taste the mellow aroma of the wine, but also feel the warmth and care from the distant rivers and lakes.

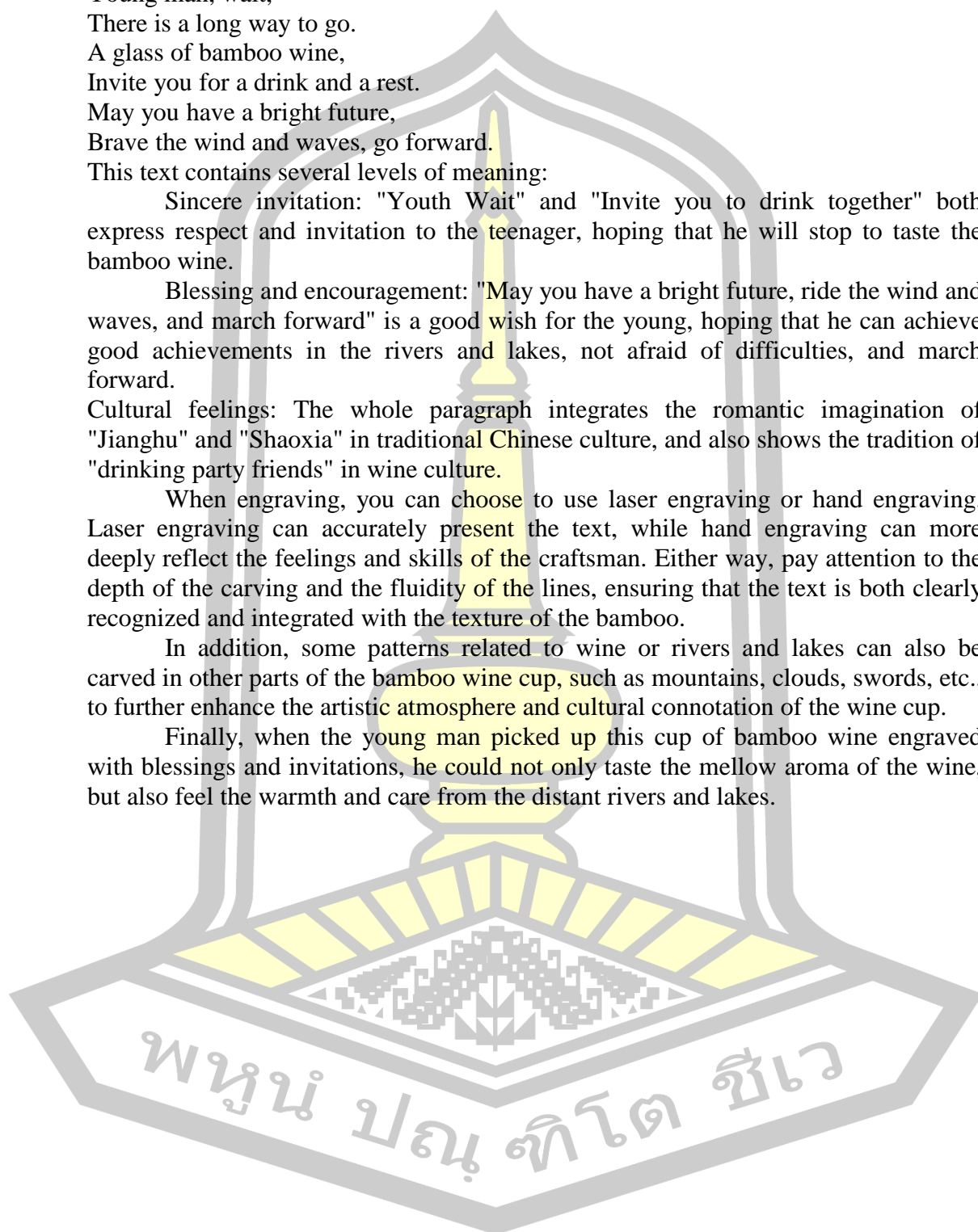

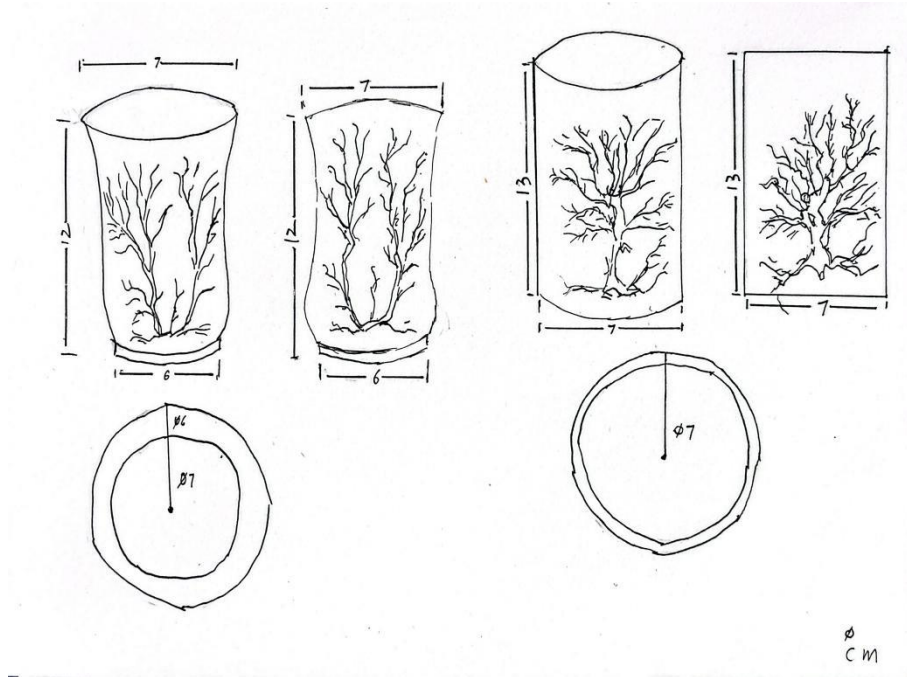

Figure 6



Figure 7



Drawing lessons from foreign videos, voltage equipment can be used to make a good-looking pattern on the board, so this way is used to reflect the simple and modern appearance of bamboo wine.

While maintaining the natural beauty of bamboo, it gives it the breath of modern science and technology.

Design to draw the pattern you want to present on the bamboo wine set, you can consider using geometric patterns, lines and other simple elements.

Design the electrode layout of the voltage device according to the pattern to ensure that the desired effect can be achieved.

#### Production process

The bamboo is processed and polished to make its surface smooth and smooth.

If necessary, a conductive coating can be applied to the surface of the bamboo to better accept the action of the voltage equipment.

The voltage treatment fixed the designed electrode layout on the bamboo to ensure good contact between the electrode and the bamboo.

The starting voltage device applies a voltage to the bamboo through an electrode. According to the different pattern and electrode layout, different burning effects can be produced, thus forming a unique pattern on the surface of the bamboo.

Follow-up treatment: After the voltage treatment is completed, the bamboo is polished and cleaned again to remove surface residues and impurities.

According to needs, some waterproof and antifouling coatings can be applied to the pattern to increase its durability and practicality.

When using the voltage device, ensure safe operation to prevent electric shock and other dangerous accidents.

Wear appropriate protective equipment, such as gloves and goggles, when using.

Control voltage: Different bamboo has different tolerance to voltage, so the voltage size and application time should be strictly controlled when using voltage equipment to avoid excessive damage to bamboo.

The effect of the pattern will be affected by many factors such as voltage size, application time, electrode layout, etc., so it is necessary to make several attempts and adjustments in actual operation to achieve the best results.

#### Design significance

This voltage treatment method creates a simple and modern pattern on the bamboo wine set, which can not only enhance the visual effect and appreciation of the wine set, but also increase its uniqueness and personalization. This design idea reflects the innovative spirit of combining tradition and modernity, and also shows the beauty of the integration of craftsmanship and technology.

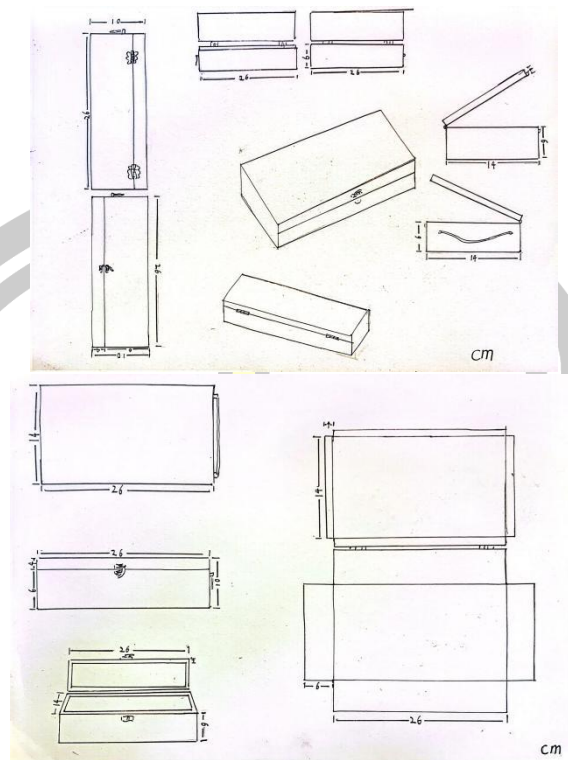

Figure 8



Figure 9

Mainly simple, bamboo is carved on the lid, ink painting and different "wine" characters are gathered into a river to represent the long history of wine culture.

Simple but not simple: Through simple lines and patterns, the simple beauty of bamboo wine sets is displayed without losing its cultural connotation.

**Bamboo and ink painting:** Bamboo as a theme element, representing the material characteristics of bamboo wine set; Ink painting shows the charm of traditional Chinese art.

**"Wine" river:** The different "wine" words are gathered into a river in the form of flow, symbolizing the long history of wine culture.

**Bamboo outline:** In the center or prominent position of the lid, a simplified bamboo outline is carved to outline the shape of the bamboo with simple lines, highlighting both the material and the beauty of nature.

**Ink background:** With a light and elegant ink background, it can be painted around the sides of the lid or around the outline of bamboo, using simple strokes and colors to create the artistic conception of traditional Chinese ink painting.

**"Wine" river:** In the background of ink painting, a flowing river is designed. The river is composed of multiple characters of "wine" in different fonts. These "wine" characters are presented in the form of flow and convergence, like a long river, symbolizing the long history and continuous inheritance of wine culture.

**Blank treatment:** Keep the overall simple style of the lid, in addition to the above elements, other parts remain blank or use light tones, so that the visual focus is on the bamboo, ink painting and "wine" word river.

**Production process:** The engraving adopts the way of hand engraving, and the designed pattern is precisely engraved on the lid. Pay attention to the depth of the carving and the fluency of the lines to ensure the clarity and beauty of the pattern.

The engraved lid is polished to make its surface smooth and smooth and feel comfortable.

**Design significance:** not only embodies the simple style of bamboo wine set, but also integrates rich cultural connotation. Bamboo and ink painting, as the representative elements of traditional Chinese culture, combine with the word "wine" river to form a unique visual effect, which not only shows the material characteristics of bamboo wine, but also conveys the long history and profound wine culture. This design not only has ornamental value, but also has a certain collection significance.

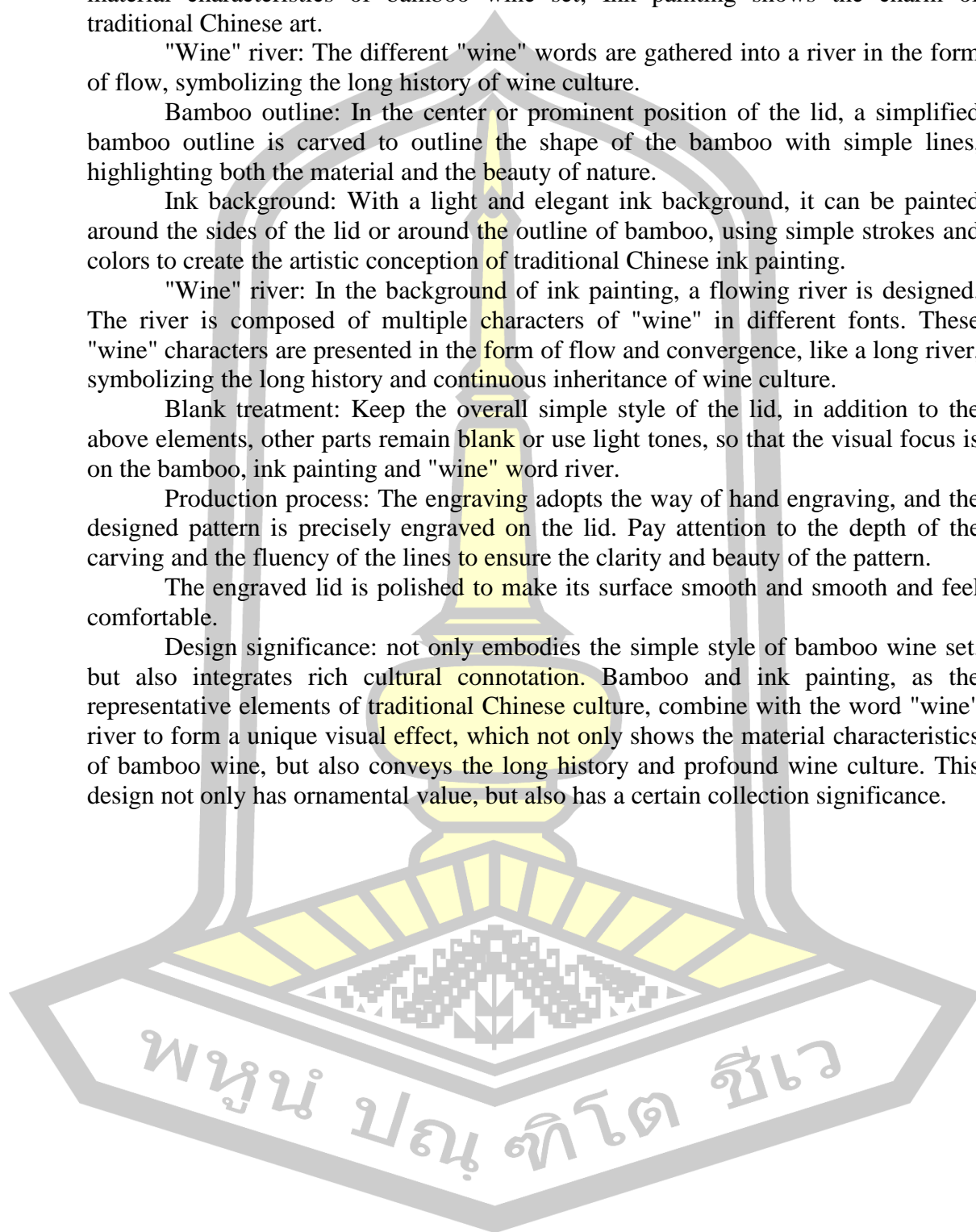

## CHAPTER V

### CONCLUSION

The famous doctor staying in Japan, the third generation of the "hundred years of Shuai gate art style", the dean of the School of Art of Guangxi University Shuai Minfeng once praised the old coal bamboo carving with "simple description of the book, beautiful image, and fine engraving of the mind to write thousands of autumn". (Qin ling 2022)

#### 5.1 Conclusion

##### 5.1.1 The current situation of bamboo wine packaging :

Bamboo wine packaging, that is, wine packaging made of bamboo. In China, bamboo wine packaging has a long history, not only has practicability, but also contains profound cultural connotation. With the development of wine market, bamboo wine packaging plays an important role in promoting brand image and inheriting culture.

The origin can be traced back to the Neolithic Age, bamboo slips, bamboo tubes and so on became the earliest form of bamboo wine packaging. With the development of history, bamboo wine packaging gradually rich, such as bamboo baskets, bamboo baskets and so on. In the Tang Dynasty, bamboo wine packaging began to integrate cultural elements, such as poetry, calligraphy, etc., reflecting the literati's love and pursuit of wine culture.

Song Dynasty: Bamboo wine packaging was further refined, bamboo weaving process was widely used, forming a bamboo wine packaging style with regional characteristics.

Ming Dynasty: With the prosperity of overseas trade, bamboo wine packaging began to absorb foreign cultural elements, showing the characteristics of diversification.

Qing Dynasty: Bamboo wine packaging reached its heyday with rich varieties and exquisite craftsmanship, which became a highlight of the wine market at that time.

Modern bamboo wine packaging design pays more attention to environmental protection, beauty and practicality. In the selection of materials, natural and pollution-free bamboo is used. Production process, the introduction of modern scientific and technological means to improve production efficiency and product quality.

Bamboo craft, that is, bamboo as the main raw material, through cutting, grinding, weaving, carving and other techniques, to produce crafts with practical value and artistic value. Its development history has a long history, as early as ancient times, people began to use bamboo to make a variety of living utensils and artworks.

With the passage of time, bamboo technology has been continuously developed and improved, and a unique charm of bamboo culture has gradually formed.

Bamboo craft not only has practical value and artistic value, but also carries rich cultural connotation and environmental protection concept. Through the inheritance and development of bamboo craft, we can carry forward and inherit the excellent traditional culture and folk art of the Chinese nation. At the same time, bamboo craft also has a unique expression in artistic creation, which can show its unique artistic charm through various methods such as carving and painting. In addition, as a green and environmentally friendly industry, bamboo technology is also in line with the concept of sustainable development in modern society.

Bamboo wine sets not only carry the inheritance of drinking culture, but also reflect people's pursuit of nature, environmental protection and health. Through the use of bamboo wine set, people can better feel the fun of drinking and taste the charm of wine culture.

Early people used bamboo to make simple wine vessels to meet the drinking needs of the time.

Bamboo wine set not only has practical value, but also has cultural value and artistic value. This paper will analyze the value of bamboo wine set in different historical periods and modern society from many angles.

The important position and function of bamboo wine set in drinking culture were revealed by analyzing its historical development, production technique and material selection.

#### 5.1.2 The wisdom of local wine packaging production :

Because of its unique geographical environment and climatic conditions, Guangxi is rich in bamboo resources, and bamboo crafts have gradually formed traditional skills with unique local characteristics, such as bamboo weaving, bamboo carving, etc. These skills have been widely passed down in the people and become the treasure of Guangxi culture.

With the development of modern society, traditional bamboo weaving techniques are facing the challenge of inheritance and protection. On the one hand, the young generation's interest in traditional handicrafts is gradually waning, leading to difficulties in inheriting skills; On the other hand, the popularization of mechanized production and the intensification of market competition have also brought impact to traditional handicrafts. In order to solve these problems, a series of measures are needed. First of all, strengthen publicity and education to improve the public's awareness and attention to traditional handicrafts; Secondly, establish the inheritor system and skill inheritance base to provide a strong guarantee for the inheritance of traditional handicrafts; Finally, strengthen policy support and capital investment to provide strong support for the development of traditional handicrafts.

The Song Dynasty was an important stage in the development of bamboo carving in Guangxi. During this period, bamboo carving skills were further improved, and the carving contents were more colorful, covering many fields such as figures, flowers and birds, and landscapes. During the Ming and Qing Dynasties, bamboo carving in Guangxi reached its heyday. Various schools and styles came into being, and the skill level reached an unprecedented height.

The bamboo carvings in Guangxi are distributed all over Guangxi, but because of the differences in geography, culture and other factors, the bamboo carvings in different places also show different characteristics. For example, the bamboo carvings in Guilin area are famous for their delicacy and delicacy, and they are good at depicting subjects such as figures, flowers and birds. The bamboo carving in Baise area pays more attention to shape and practicality, and the style is rough and bold.

In addition, ethnic minorities in Guangxi have also incorporated their own elements and characteristics into the art of bamboo carving. For example, the bamboo carvings of the Zhuang people are often decorated with Zhuang brocade, bronze drums and other ethnic patterns, reflecting the strong national cultural atmosphere.

Guangxi bamboo carving techniques include material selection, design, cutting, grinding, carving and other links. In terms of material selection, bamboo carvers will choose bamboo with strong texture and clear texture as raw materials. In the design process, the artist will carry out ingenious conception and design according to the shape and material characteristics of bamboo. During the cutting and grinding process, the bamboo is finely processed and treated with various tools. Finally, the design pattern or image is engraved on the bamboo through the carving technique to complete the work.

Guangxi bamboo wine set is a wine set made of bamboo as raw material and processed by exquisite technology. Its variety, including bamboo wine cylinder, bamboo wine pot, bamboo wine glasses and so on. These bamboo wine sets not only have practical value, but also have unique artistic charm and cultural connotation. In the local history and culture, Guangxi bamboo wine set occupies an important position and becomes an important part of folk drinking culture.

Generation. With the changes of The Times and the development of society, the production techniques and types of bamboo wine sets in Guangxi are constantly enriched and developed. In different historical periods, the interaction between Guangxi bamboo wine set and local social politics, economy and culture also showed different characteristics. From the initial simple and practical to the later exquisite decoration, the development of Guangxi bamboo wine set reflects the inheritance and development of local culture.

Through the investigation and analysis of the actual use in the current market or rural areas, we found that Guangxi bamboo wine set still has a certain market demand in the folk. However, with the acceleration of modernization and the change of people's lifestyle, Guangxi bamboo wine set is facing some challenges and problems. Such as shortage of raw materials, difficulties in inheriting production skills, fierce market competition and so on. These problems need us to take effective measures to solve them.

Strengthen the understanding of its historical and cultural value, and take effective measures to strengthen the inheritance and protection of this folk art form, so that it can be inherited and developed for the benefit of future generations.

### 5.1.3 Design and develop packaging for local smart bamboo wine :

In the design process, we pay attention to the combination of traditional cultural elements and modern aesthetics, and show the unique charm of traditional Chinese culture through bamboo carving works. For example, in the selection of the

theme of the work, we selected elements with traditional Chinese cultural characteristics to present them vividly through bamboo carving techniques.

In the actual production process, the following main techniques were summarized:

**Precision cutting:** The use of professional tools to accurately cut the bamboo to ensure the accuracy of the shape and size of the work.

**Fine carving:** The use of carving knives and other tools to finely carve bamboo, showing a delicate texture and a sense of hierarchy.

**Clever combination:** Through splicing, Mosaic and other ways to combine different shapes of bamboo carvings into a complete work, showing a rich visual effect.

As the product of the blend of tradition and modernity, bamboo wine set has a long historical background and unique cultural value. With the improvement of people's environmental awareness and the pursuit of life quality, bamboo wine set has been more and more applied in modern life. It not only carries the essence of traditional culture, but also shows the innovative charm of modern design.

In this study, the design concept adopted focuses on the uniqueness and practicability of bamboo wine sets. Through in-depth research on traditional culture and market demand, the traditional bamboo art is combined with modern design concept, and strives to meet the aesthetic and use needs of modern people while maintaining the traditional charm. Our creativity is reflected in the clever use of bamboo and the innovative design of the shape, making bamboo wine sets not only have a unique artistic beauty, but also have practicality and durability.

In the process of making bamboo wine sets, we have gone through a number of key steps, including material selection, bamboo treatment, shape design and processing. Attention to detail and quality control. Through these measures, we successfully completed the production of bamboo wine set, and guaranteed the quality and beauty of the product.

Compared with other material products, bamboo wine set has significant advantages and characteristics. First of all, bamboo is a renewable resource, the use of bamboo wine set is in line with the concept of environmental protection; Secondly, bamboo has unique texture and color, which makes bamboo wine set have unique artistic beauty; Finally, the bamboo wine set also has excellent thermal insulation and sealing performance, which can ensure the stable quality of the wine in the storage and transportation process.

## **5.2.Discussion**

Guangxi is located in the south, the climate is warm and humid, bamboo and wood resources are rich, for the development of bamboo technology provides sufficient raw materials. Local mainly uses bamboo, bamboo and other varieties of crafts production.

The craft has a long history and exquisite skills. In the long-term practice, Guangxi bamboo craft teachers have accumulated rich experience and skills, and can make exquisite bamboo products according to different materials and needs.

The combination of local national culture, traditional customs and artistic characteristics has formed a unique artistic style. In bamboo crafts, we can often see

traditional cultural elements and totems such as dragon, phoenix and peony, which are rich in regional culture.

As early as the Han Dynasty, the bamboo weaving technology in Guangxi has been quite developed. During the Southern and Northern Dynasties, bamboo craft of a certain scale and influence had been formed. During the Ming and Qing Dynasties, the bamboo craft in Guangxi developed to its heyday, and the bamboo craft was constantly innovated, forming the Guangxi bamboo craft school with its unique style and skills.

In the middle of the Ming Dynasty, the use was further expanded, and more and more attention was paid to creating many high-grade bamboo vessels. For example, a painting box for painting and calligraphy, a small round box for jewelry, and a large round box for food. In the period of the Republic of China, bamboo weaving equipment has become one of the important local light industrial products. Before the 1950s, bamboo weaving was mainly based on the self-sufficient production method of the people. With the changes of The Times, bamboo craft in Guangxi has gradually developed and expanded, becoming one of the important local cultural industries.

**Skill inheritance:** The inheritance of Guangxi bamboo craft mainly relies on two ways: family inheritance and master and apprentice inheritance. Many bamboo craft masters pass on their skills to the next generation or apprentices, ensuring the inheritance and development of bamboo craft skills. In recent years, Guangxi bamboo craft has been continuously innovative and developed on the basis of inheritance. On the one hand, the introduction of modern design concepts and scientific and technological means, improve the traditional process, improve the production efficiency and quality of products; On the other hand, combined with market demand and consumer preferences, new styles and newly designed products are launched to meet the diversified needs of the market.

**Bamboo weaving technique:** Guangxi bamboo weaving technique is unique, mainly using warp and weft weaving method, combined with thinning knitting, inserting, threading, cutting, locking, nailing, tying, set and other techniques for weaving. This technique can weave bamboo products of various shapes and patterns, such as bamboo baskets, bamboo baskets and so on.

**Bamboo carving techniques:** Guangxi bamboo carving techniques are mainly based on calligraphy bamboo slips and old coal bamboo carving techniques. This technique needs to be completed through the bamboo selection, cleaning, cutting, planing, polishing, fine grinding, piercing, design, writing, painting, oil, engraving, coloring, painting, waxing and other processes. The final work has unique artistic value and collection value.

In the design, it integrates the local national culture and artistic characteristics, forming a unique charm of local characteristics products.

In health and environmental protection, bamboo wine set is non-toxic and harmless, easy to clean and maintain, in line with modern people's pursuit of healthy and environmental life.

**Selection of materials:** Select high-quality bamboo as raw materials to ensure the durability and beauty of the wine set.

**Cutting:** According to the design requirements, the bamboo is cut to the appropriate size and shape.

**Grinding:** Grinding the cut bamboo to make its surface smooth and smooth.

**Assembly:** The various components are assembled together through drilling, interspersing and other processes to form a complete wine set.

**Decoration:** According to the needs of carving, painting and other decorative processing, enhance the artistic value of the wine set.

There are many kinds of bamboo wine utensils, including bamboo tubes, bamboo cups, bamboo wine POTS and so on. These wine sets have their own characteristics, not only have practical functions, but also integrate rich national culture and aesthetic elements.

**Bamboo tube:** Bamboo tube is one of the most common bamboo wine utensils in Guangxi, with moderate capacity and easy to carry. Its design is simple and elegant, smooth lines, suitable for daily drinking, but also suitable for festival banquets and other occasions.

**Bamboo cup:** Bamboo cup is loved by people for its unique shape and texture. Its shape is inspired by the natural form of bamboo, and presents an elegant and simple aesthetic feeling through fine carving and polishing techniques. Exquisite, unique shape, is the collection and gift of good.

**Bamboo wine pot:** Bamboo wine pot with bamboo as the main raw material, combined with modern design concepts and technology, to create a practical and artistic wine set. Its design

When integrating ancient craft knowledge into modern design, we need to find a suitable integration strategy. This involves the selection, refinement and re-creation of traditional elements, as well as the organic combination with modern design concepts. Through the clever fusion, we can create a bamboo wine container with both traditional charm and modern sense, to meet the aesthetic needs of modern consumers.

As a renewable resource, bamboo has great potential in today's increasingly popular concept of environmental protection. We need to explore the innovative application of bamboo, such as new bamboo weaving process, bamboo surface treatment technology, etc., to improve the performance and beauty of bamboo wine containers. At the same time, we also need to pay attention to the embodiment of environmental protection concepts, such as optimizing product structure design, reducing material waste, etc., to promote the sustainable development of bamboo wine containers.

As consumer demand for personalized products continues to grow, the design of bamboo wine containers also needs to adapt to this trend. We can meet the individual needs of consumers by providing customized design schemes and introducing personalized elements. This can not only enhance the added value of products and market competitiveness, but also bring a more unique experience to consumers.

Modern technology provides strong support for bamboo wine container design. However, while using these technological means for innovation and development, we also face some challenges and opportunities. For example, how to combine these technical means with traditional craft knowledge, how to maintain the uniqueness of products and handicraft value are all problems that we need to think about and solve.

Ancient Chinese bamboo wine container design is full of wisdom and ingenuity. Traditional bamboo weaving techniques, carving techniques, color application, etc., are worthy of reference and learning by modern designers. These ancient craft knowledge is not only a technology, but also a cultural and spiritual inheritance. In the new design, the traditional elements and symbols can be refined and recreated to make the bamboo wine container glow with new vitality and charm.

Modern design concepts focus on simplicity, practicality, environmental protection and sustainability. In the design of bamboo wine containers, these ideas can be applied to create works that are both beautiful and practical. For example, the natural beauty of bamboo is expressed through simple lines and geometric shapes; By optimizing the structure design, the sealing and insulation performance of the container are improved. Environmental protection and sustainability are highlighted by the selection of renewable, recyclable bamboo as a material.

Combining traditional craft knowledge with modern design concept is the core of bamboo wine container design. Designers can use modern design techniques to carry out innovative design through the deconstruction and reconstruction of ancient wine vessels. At the same time, it can also learn from the decorative techniques of ancient wine vessels to add unique artistic charm to modern bamboo wine containers.

Simple design: Modern design emphasizes simplicity, removes redundant decoration and complex structure, and expresses design concept with simple lines and forms. In the design of bamboo wine containers, the principle of simplicity can be used to reduce excessive carving or decoration, and highlight the natural texture and texture of the bamboo itself. In the shape, we can pursue simple geometric shapes to reflect the aesthetic of modern design.

Modern design focuses on practicality, emphasizing product function and user experience. In the design of bamboo wine container, the practical factors such as tightness, heat preservation and easy cleaning should be fully considered. Through reasonable structural design and material selection, to ensure the stability and convenience of the container during use.

Modern design promotes environmental protection and sustainability. As a natural and environmentally friendly packaging material, bamboo wine containers have high sustainable utilization value. In the design process, the recyclability of bamboo should be fully utilized to reduce waste and pollution. At the same time, environmentally friendly production processes and decorative means can be used to make bamboo wine containers more in line with the environmental protection needs of modern consumers.

Modern design emphasizes the integration of culture and art. In the design of bamboo wine containers, traditional Chinese cultural elements can be combined with modern design techniques to form a unique artistic style. For example, artistic techniques such as calligraphy and painting can be used on containers to show the charm of traditional Chinese culture. At the same time, we can also pay attention to the development trend of modern art, integrate contemporary art elements into the design, and add a modern sense to the bamboo wine container.

To integrate modern design concepts into the design of bamboo wine containers, it is necessary to pay attention to simple design, pragmatism, environmental protection concepts, technological innovation and the integration of culture and art.

Bamboo is a fast-growing and renewable plant resource, and the choice of bamboo as the main material is itself an environmentally friendly and sustainable choice. In the design, the renewability of bamboo should be fully utilized to reduce the dependence on other non-renewable resources.

In the design process, attention should be paid to optimizing the use of materials and avoiding waste. For example, we can reduce the unnecessary use of bamboo through reasonable structural design, or use bamboo scraps for creative design, so that it can also play a role.

Try to choose environmentally friendly production technology and decoration means. For example, non-toxic and pollution-free coatings and adhesives can be used to avoid pollution to the environment.

Environmental sustainability in the design needs to be comprehensively considered from many aspects such as material selection, material use, production process and structural design.

The shape of bamboo elements uses different forms of bamboo, such as tall and straight bamboo poles, slender bamboo nodes, lush bamboo leaves, etc., which provide a rich source of inspiration for designers. In the design of bamboo wine containers, the shape of bamboo elements can be extracted, simplified and reconstructed to create both traditional charm and modern style. For example, using the shape of bamboo joints to design a unique concave and convex texture, or transforming the shape of bamboo leaves into a decorative pattern of containers, are effective ways to use form.

The texture of bamboo elements expresses the warm and natural texture of bamboo, giving people a fresh and refined feeling. In the design of bamboo wine container, the unique texture beauty can be highlighted through the treatment and processing of bamboo. For example, using the primary color of bamboo or applying a transparent paint layer, so that the natural texture and color of bamboo can be fully displayed; Or through the bamboo grinding, carbonization and other treatment, to create a simple and elegant visual effect.

In traditional Chinese culture, bamboo is one of the "three friends of the cold", symbolizing the quality of noble, tough and modest. In the design of bamboo wine containers, these cultural meanings can be incorporated to make the works have deeper cultural connotations. For example, through the use of bamboo elements to design a simple and elegant container shape, convey a simple but not simple design concept; Or through carving, inlay and other techniques, on the container to express bamboo cultural patterns or poems, in order to enhance the cultural heritage of the work.

The history of bamboo carving in Guangxi can be traced back to the Neolithic Age or even earlier, but it really formed a unique style and skill system, and had a greater influence on the whole country, mainly in the Ming and Qing dynasties. During this period, the Guangxi bamboo carving and the Central Plains carving art learned from each other, integrated and developed, and formed the unique Guangxi bamboo carving art.

Guangxi bamboo carving pays attention to the combination of practicality and beauty in the design style. The works have a wide range of themes, including figures, landscapes, flowers and birds, fish and insects, etc. The forms are relief, transparent carving, round carving, etc., with fine techniques and diverse styles.

The carving techniques of bamboo carving in Guangxi include flat knife method, round knife method, oblique knife method, etc., through the skillful use of these techniques, the engravers create the works with distinct layers and strong three-dimensional sense.

The raw materials of bamboo carving in Guangxi are mainly bamboo, and the texture, texture and color of bamboo are emphasized in the selection of materials. The selected bamboo needs to be cleaned, dried, mildew resistant and other treatment to improve its durability and service life. Before carving, the bamboo also needs to be skinned, cut and other primary processing.

The production process of bamboo carving in Guangxi includes bamboo selection, bamboo cutting, design, carving, grinding, painting and other processes. During the production process, the engraver needs to carefully carve every detail to ensure the overall effect of the work. At the same time, with the development of modern science and technology, some new craft technologies and materials have also been introduced into the production of bamboo carving, such as laser engraving technology, natural pigments, etc., so that bamboo carving works are more modern and fashionable while maintaining traditional characteristics.

Color and pattern are not only an important part of the visual arts, but also often carry profound cultural significance. In the design of bamboo wine containers, the use of traditional colors and patterns can not only enhance the aesthetic value of the containers, but also let users feel the charm of traditional Chinese culture.

Traditional colors have unique symbolic significance in Chinese culture. For example, red represents happiness and auspiciousness, yellow symbolizes imperial power and honor, blue represents tranquility and far-reaching, and green symbolizes life and hope. In the design of bamboo wine container, the specific cultural connotation can be expressed by choosing appropriate traditional colors. For example, the use of red or gold decorative lines and patterns to give the wine container a festive and noble atmosphere; Or use blue and green bamboo colors to show a fresh and natural style.

The use of traditional patterns: there are many kinds of traditional patterns in China, such as dragon and phoenix, moire pattern, Hui pattern, lotus pattern, etc., each of which has its own unique cultural connotation and aesthetic value. In the design of bamboo wine containers, these traditional patterns can be used as decorative elements to increase the artistic and cultural depth of the containers. For example, carving or drawing dragon and phoenix patterns on the surface of containers can symbolize auspiciousness and beauty; The use of moire or back as a border or background decoration can create a mysterious and elegant atmosphere.

In the design of bamboo wine containers, the combination of color and pattern is also very important. Designers need to choose the right color and pattern to match according to the shape, function and use scene of the container. For example, for a simple bamboo wine container, a single bamboo color can be used as the keynote, and then gold or red lines and patterns are embellished to highlight its elegant and festive characteristics.

Innovation and tradition In the use of traditional colors and patterns, but also need to pay attention to innovation. Try to combine traditional elements with modern design concepts to create a bamboo wine container with both traditional charm and modern aesthetic needs. Using modern color matching and pattern combination, the

traditional elements are re-created and reconstructed to make them more in line with modern aesthetic needs.

With its unique national characteristics, green environmental protection concept and innovative design, Guangxi bamboo wine set design shows infinite charm and potential in inheritance and development.

Bamboo wine set design has unique advantages and cultural connotation. By following the design concepts of environmental protection, aesthetics and practicality, selecting appropriate bamboo and conducting scientific treatment, and realizing reasonable structural design and process production and optimization, bamboo wine sets will show stronger competitiveness in the market. At the same time, expanding application areas and implementing sustainable development strategies will help promote cultural inheritance and environmental protection.

As a cultural product with local characteristics, it will gradually attract the attention and love of more countries. In the future, bamboo wine set design will continue to develop and grow in inheritance and innovation.

### **5.3.Suggestions**

Guangxi bamboo technology is relatively backward in technical level, lack of advanced production equipment and processing technology. This results in uneven product quality, which is difficult to meet market demand.

The types of bamboo craft products in Guangxi are relatively simple and lack of innovation. The common bamboo crafts in the market are mainly in traditional styles, which is difficult to attract young consumers.

Due to the factors such as technical level, product quality and single variety, the share of Guangxi bamboo craft products in the domestic market is relatively small, and the competitiveness of the international market is weak.

Publicity and promotion efforts are small, lack of effective marketing strategies and means. This leads to low consumer awareness and limits product sales.

Suggestion : Support the introduction of advanced equipment and technology to improve product quality and process level. Strengthen market research and product research and development, combine modern aesthetic and consumer demand, innovate product design, and build bamboo craft brand with local characteristics. At the same time, we will strengthen cooperation with universities and research institutions to promote the deep integration of industry, university and research. Strengthen the cooperation and exchange between bamboo craft and design industry, and introduce modern design concepts and methods to improve the design level and creativity of bamboo products. Designers are encouraged to integrate bamboo craft elements into other design fields to form cross-border design innovations

Tourism industry: Combining the tourism resources of Guangxi, bamboo carving and tourism industry will be combined to create tourism souvenirs and handicrafts with local characteristics.

Design industry: Strengthen cooperation and exchanges with the design industry, introduce modern design concepts and elements, and improve the design level and innovation of bamboo carving products.

Guangxi's bamboo forest area reached 7 million mu, the growth rate ranked first in the country. Bamboo wine set has a long history, and the traditional production technology has been well inherited. However, with the development of modern industry, traditional handicraft is facing the problem of the fault of inheritors.

With the improvement of people's living standard and the increase of cultural consumption demand, the demand for bamboo wine sets with cultural characteristics and artistic value is growing. However, the current bamboo wine set on the market is relatively simple, and the design lacks innovation.

The change of market demand directly affects the production and sales of bamboo wine set in Guangxi. Consumer demand for bamboo wine sets in terms of quality, design and cultural value is increasing.

Inheritors are the core of the industry. The key to development is to strengthen the training of talents and improve the skill level and innovation ability of inheritors.

Suggestion : On the basis of inheriting the traditional production process, strengthen innovation, and promote the design innovation, material innovation and technical innovation of Guangxi bamboo wine set. Combined with modern design concept, develop more new bamboo wine sets that meet the market demand.

Expand the market scope of bamboo wine set through promotion and cultural exchange. To promote Guangxi bamboo wine set to the national and even global market, improve its popularity and reputation.

In the design of Guangxi bamboo wine set, we should fully consider regional culture, folk art and modern aesthetic elements. We can draw inspiration from Guangxi's natural scenery, ethnic customs and historical culture, combine traditional elements with modern design, and create bamboo wine sets that both have traditional charm and meet modern aesthetic needs. For example, the Zhuang brocade pattern of Guangxi can be applied to the appearance design of the wine set, so that it has more regional characteristics and cultural connotation.

When making bamboo wine sets, high-quality bamboo should be selected as raw materials. At the same time, in order to ensure the safety, health and durability of the product, we need to carry out strict selection and treatment of bamboo. In terms of surface treatment technology, grinding, polishing, coloring and other processes can be used to make the surface of the wine more smooth and beautiful, and enhance its waterproof, mildew and other properties.

In order to meet the needs of different consumers, we should develop various types of bamboo wine products, such as bamboo cup, bamboo mat incubator. At the same time, you can also consider adding some additional functions on the wine set, such as intelligent temperature control, sound insulation design, etc., to enhance the competitiveness of the product. In addition, we can also develop corresponding products for different use scenarios, such as outdoor picnics, family gatherings, etc., to meet the diversified needs of consumers.

Suggestion : Through market investigation and analysis, we found that the current consumer demand and preference for bamboo wine sets show a diversified trend. On the one hand, consumers have shown great interest in bamboo wine sets with traditional cultural characteristics; On the other hand, the modern aesthetic concept and lifestyle also urge consumers to put forward higher requirements for the design and function of bamboo wine sets.

Environmental protection: Bamboo is a renewable resource with a short growth cycle and is friendly to the environment. The use of bamboo wine sets can reduce the dependence on non-renewable resources and reduce environmental pollution.

**Aesthetic:** Bamboo has natural texture and color, which makes bamboo wine set more natural and rustic in appearance. At the same time, the flexibility and plasticity of bamboo also provide designers with more creative space.

**Durability:** Bamboo has high strength and toughness, which makes the bamboo wine set not easy to be damaged during use and has high durability.

**Ergonomic:** The design of the wine set should fully consider the ergonomic principle, so that people feel comfortable and convenient when using. For example, the caliber, height and shape of the wine glass should be adapted to the structure of the person's hand and drinking habits.

**Innovative design:** On the basis of maintaining the characteristics of traditional bamboo wine, integrating modern design concepts and scientific and technological elements, innovative design is in line with modern aesthetic and use habits of new wine sets.

In order to enhance the artistic and cultural connotation of bamboo wine sets, traditional Chinese cultural elements can be incorporated into the design, such as:

**Landscape painting:** Applying landscape painting elements to the appearance design of wine sets can make the products more poetic and aesthetic.

**Calligraphy font:** Writing or branding calligraphy font on the wine set not only shows the charm of traditional Chinese culture, but also enhances the cultural value and collection value of the product.

In the design of bamboo wine set, we should fully consider its environmental protection, beauty, durability and other characteristics and advantages, and follow the ergonomic principle and innovative design ideas. At the same time, in the shape and decorative elements into the traditional Chinese cultural elements, to enhance the artistic and cultural connotation of the product. Finally, we need to carefully select and handle raw materials to ensure the quality and durability of our products. Through continuous efforts and innovation, it is believed that bamboo wine sets will become an indispensable part

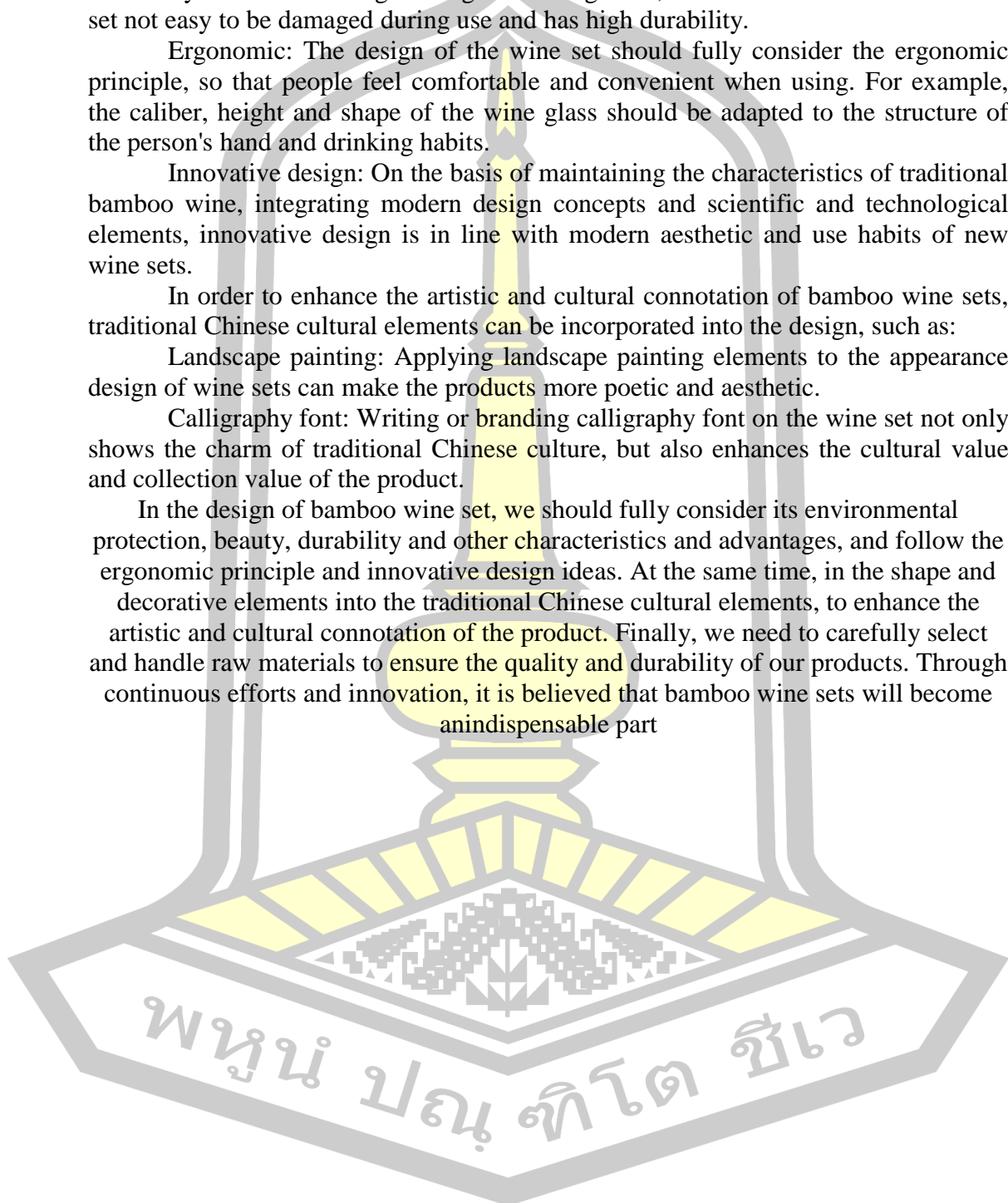

**REFERENCES**

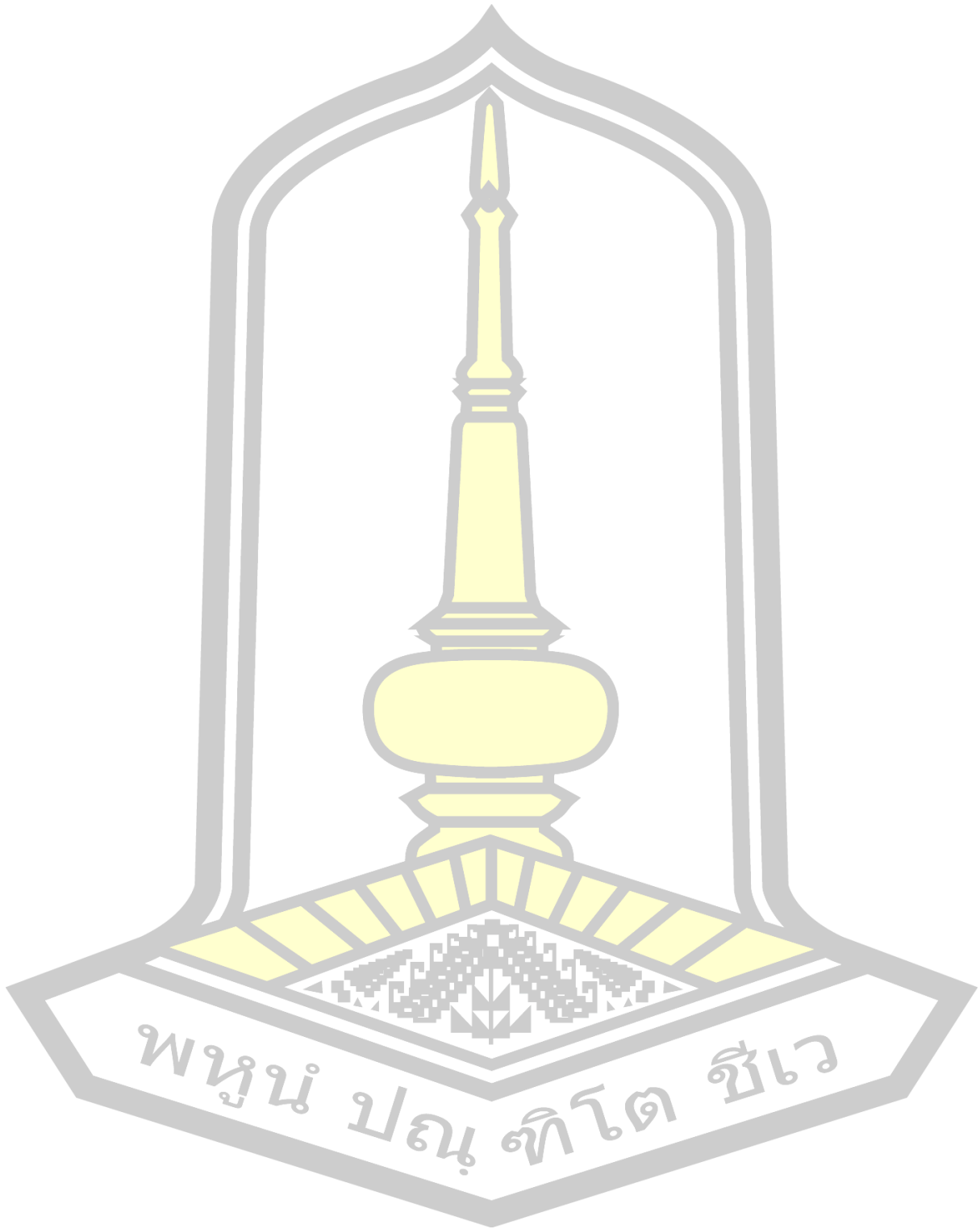

Zhang Xiaokai(2021) Write a book about Bamboo creation History of Chinese bamboo ware and production technology

Joseph Terence Montgomery Needham (1954) Write a book about Science and Civilization in China

Xu Mao-qi Cao Jie(2014) Write a book about A brief discussion on the design and innovation of bamboo weaving products

Mu Rongbing, Ning Shaoqiang (2011) Write a book about Market development and redesign strategy of traditional bamboo handicrafts in Guangxi

Wang Xiaoge, Liu Jun (2020) Write Article About Cultural assignment and value reconstruction of contemporary bamboo craft

Dai Yanling (2020) Write Article About Analysis on the artistic characteristics of bamboo weaving in Shidong town, Suining

CAI Yushuo, Huang Qingqing, Zhu Weijun (2021) Write Article About Bamboo weaving is regarded as the intangible cultural heritage of Henan Province

Wang Hao (2023) Write book About Research on inheritance, innovation and development of bamboo weaving skills of Dai nationality

Li Shizhen (1578) Write book About Compendium of Materia Medica

Zuo Kecheng, Yang Qiang, TONG Guoqiang, Le Xixuan, SHI Peng, Guan Ying (2009) Write Artic about Study on quality stability of liquor by storage environment and packing method

(Wang Xin, Jin Rong, Liu, Yang Chuncheng, Qing, Wang Weiyong 2020) How to store white wine will not run wine

Zhong Shujia Sun Yutong(2017) Write Article about Bamboo culture in modern packaging design interpretation

Wu Jiahui, Wang Yunfang, Zhu Chenxi(2014) Write Article about On the application of traditional Chinese elements in the packaging design of bamboo chopsticks

Xia Hongrui (2013) Write Article about Nature and design

Wang Gege (2015) Write book about Research on the application of bamboo elements in the design of modern Chinese dining space

Gu Xiaoping (2021) Write book about Packaging design under the modern concept

Shi Xiaoxia (2021) Write book about The application of bamboo in packaging design

[Day] Rongjiu Ankenji, Noguchi Runri, Iba Masato, et al. Expanding design - Design principles from GK Group, Japan

Thoughts and Practice [M]. Yang Xiangdong, Zhan Zhengmin, Zhan Yihong, Trans. Changsha: Hunan Science and Technology Press, 2004.

Da Zhihao, Sakuchi Shiro, Introduction to Design [M]. Zhang Fuchang, trans. Hangzhou: Zhejiang People's Fine Arts Publishing Society, 1991.

Stefano Marzano. Design for diversity, let us begin! [J] INNOVATION 2003(spring):41.

[Netherlands] Stefano Marzano. Design Creates Value - Philips Design Thought [M]. CAI Jun, SONG Huang,

- Xu Haisheng, Trans. Beijing: Beijing Institute of Technology Press, 2002.  
Rolf Jense, The Dream Society [M]. New York: McGraw Hill, 1999.  
Ross Lovegrove. The international design yearbook 2002 [M] Laurence King Publishing, 2003.  
Thomas Kuhn, The Structure of Scientific Revolution [M]. Jin Wulun, Hu Xinhe, trans. Beijing: Beijing Big Academic Press, 2003.  
He Ming, Liao Guoqiang. Research on Chinese bamboo culture [M].  
Alan Bowers. Natural design [M]. Press, 200

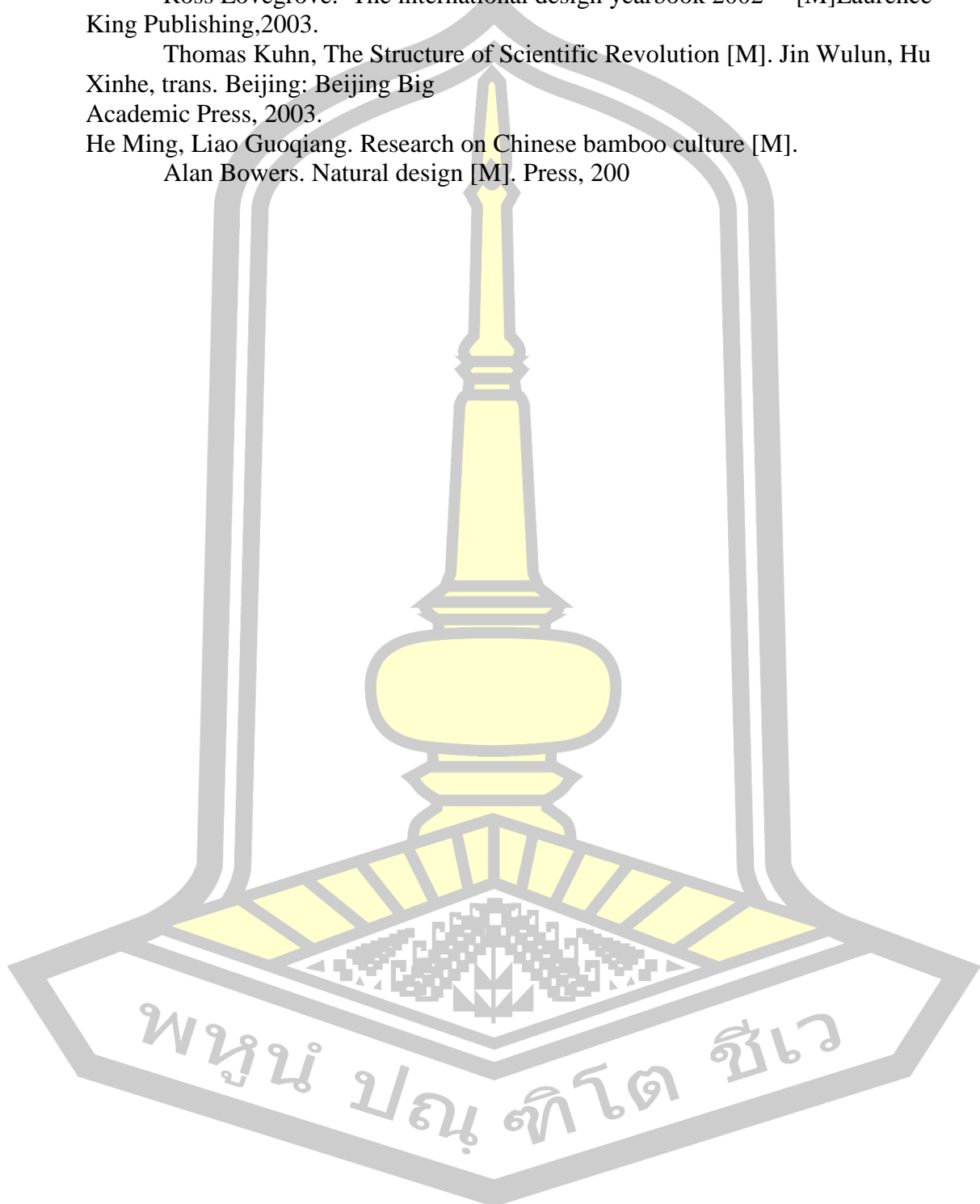

## BIOGRAPHY

<b>NAME</b>	Zhang Zhikai
<b>DATE OF BIRTH</b>	26 November 1998
<b>PLACE OF BIRTH</b>	Nanning, Guangxi Zhuang Autonomous Region, China
<b>ADDRESS</b>	Nanning, Guangxi Zhuang Autonomous Region, China
<b>POSITION</b>	Nanning, Guangxi Zhuang Autonomous Region, China
<b>PLACE OF WORK</b>	Student
<b>EDUCATION</b>	2021-2024 Master from Faculty of Fine - Applied Arts and Cultural Science Mahasarakham University

